

CiA Draft Standard 401

CANopen

Device Profile for Generic I/O Modules

Version 2.1

Date: 17 May 2002

© CAN in Automation (CiA) e. V.

Table of contents

1	Scope	7
2	Normative references	7
3	Definitions, acronyms and abbreviations	7
4	Operating principle	8
4.1	Introduction	8
5	Error handling	8
5.1	Principle.....	8
5.2	Error behaviour.....	8
5.3	Additional error code meanings.....	9
6	Pre-definitions	10
6.1	Introduction	10
6.2	Pre-defined communication objects.....	10
6.2.1	Device type (1000 _h).....	10
6.2.2	Error Register (1001 _h).....	10
6.2.3	Error Behaviour (1029 _h).....	11
6.2.4	1st RPDO mapping (digital outputs)	12
6.2.5	1st TPDO mapping (digital inputs).....	13
6.2.6	2nd RPDO mapping (analogue outputs).....	14
6.2.7	2nd TPDO mapping (analogue inputs).....	15
6.2.8	3rd RPDO mapping (analogue outputs).....	16
6.2.9	3rd TPDO mapping (analogue inputs)	17
6.2.10	4th RPDO mapping (analogue outputs).....	18
6.2.11	4th TPDO mapping (analogue inputs)	19
7	Object dictionary	20
7.1	Input and output function principles	20
7.1.1	Object dictionary for the digital input and output modules	20
7.1.2	Digital input module	21
7.1.3	Digital output module	23
7.1.4	Analogue input module.....	25
7.1.5	Analogue output module.....	26
7.1.6	Analogue input set-ups.....	27
7.1.7	Analogue output set-ups.....	27
7.1.8	General device profile objects.....	27
8	Object descriptions	28

8.1	Digital input module	28
8.1.1	Read Input 8-Bit (6000h)	28
8.1.2	Polarity Input 8-Bit (6002 _h).....	30
8.1.3	Filter Constant Input 8-Bit (6003 _h).....	31
8.1.4	Global Interrupt Enable Digital 8-Bit (6005 _h).....	32
8.1.5	Interrupt Mask Any Change 8-Bit (6006 _h).....	33
8.1.6	Interrupt Mask Low-to-High 8-Bit (6007 _h).....	34
8.1.7	Interrupt Mask High-to-Low 8-Bit (6008 _h).....	35
8.1.8	Read Input Bit 1 to 128 .. Read Input Bit 897 to 1024 (6020 _h .. 6027 _h).....	36
8.1.9	Polarity Input Bit 1 to 128 .. Polarity Input Bit 897 to 1024 (6030 _h .. 6037 _h).....	37
8.1.10	Filter Constant Input Bit 1 to 128 .. Filter Constant Input Bit 897 to 1024 (6038 _h .. 603F _h).....	38
8.1.11	Interrupt Mask Input Any Change Bit 1 to 128 .. Interrupt Mask Input Any Change Bit 897 to 1024 (6050 _h .. 6057 _h).....	39
8.1.12	Interrupt Mask Input Low-to-High Bit 1 to 128 .. Interrupt Mask Input Low-to-High Bit 897 to 1024 (6060 _h .. 6067 _h).....	40
8.1.13	Interrupt Mask Input High-to-Low Bit 1 to 128 .. Interrupt Mask Input High-to-Low Bit 897 to 1024 (6070 _h .. 6077 _h).....	41
8.1.14	Read Input 16-bit (6100 _h).....	43
8.1.15	Polarity Input 16-bit (6102 _h)	44
8.1.16	Filter Constant Input 16-bit (6103 _h).....	45
8.1.17	Interrupt Mask Input Any Change 16-bit (6106 _h).....	46
8.1.18	Interrupt Mask Input Low-to-High 16-bit (6107 _h)	47
8.1.19	Interrupt Mask Input High-to-Low 16-bit (6108 _h)	48
8.1.20	Read Input 32-bit (6120 _h).....	49
8.1.21	Polarity Input 32-bit (6122 _h)	50
8.1.22	Filter Constant Input 32-bit (6123 _h).....	51
8.1.23	Interrupt Mask Input Any Change 32-bit (6126 _h).....	52
8.1.24	Interrupt Mask Input Low-to-High 32-bit (6127 _h)	53
8.1.25	Interrupt Mask Input High-to-Low 32-bit (6128 _h)	54
8.2	Digital output module	55
8.2.1	Write Output 8-Bit (6200 _h).....	55
8.2.3	Change Polarity Output 8-Bit (6202 _h).....	56
8.2.4	Error Mode Output 8-Bit (6206 _h).....	57
8.2.5	Error Value Output 8-Bit (6207 _h).....	58
8.2.6	Filter Mask Output 8-Bit (6208 _h).....	60
8.2.7	Write Output Bit 1 to 128 .. Write Output Bit 897 to 1024 (6220 _h .. 6227 _h).....	61
8.2.8	Change Polarity Output Bit 1 to 128 .. Change Polarity Output Bit 897 to 1024 (6240 _h .. 6247 _h).....	62
8.2.9	Error Mode Output Bit 1 to 128 .. Error Mode Output Bit 897 to 1024 (6250 _h .. 6257 _h).....	63
8.2.10	Error Value Output Bit 1 to 128 .. Error Value Output Bit 897 to 1024 (6260 _h .. 6267 _h).....	64
8.2.11	Filter Mask Output Bit 1 to 128 .. Filter Mask Bit 897 to 1024 (6270 _h ..6277 _h).....	65

8.2.12	Write Output 16-bit (6300 _h).....	67
8.2.13	Change Polarity Output 16-Bit (6302 _h).....	68
8.2.14	Error Mode Output 16-Bit (6306 _h).....	69
8.2.15	Error Value Output 16-Bit (6307 _h).....	70
8.2.16	Filter Mask Output 16-Bit (6308 _h).....	71
8.2.17	Write Output 32-Bit (6320 _h).....	72
8.2.21	Change Polarity Output 32-Bit (6322 _h).....	73
8.2.22	Error Mode Output 32-Bit (6326 _h).....	74
8.2.23	Error Value Output 32-Bit (6327 _h).....	75
8.2.24	Filter Mask Output 32-Bit (6328 _h).....	76
8.3	Analogue input module.....	77
8.3.1	Read Analogue Input 8-Bit (6400 _h).....	77
8.3.2	Read Analogue Input 16-Bit (6401 _h).....	78
8.3.3	Read Analogue Input 32-Bit (6402 _h).....	80
8.3.4	Read Analogue Input Float (6403 _h).....	81
8.3.5	Read Manufacturer-specific Analogue Input (6404 _h).....	82
8.4	Analogue output module.....	83
8.4.1	Write Analogue Output 8-Bit (6410 _h).....	83
8.4.2	Write Analogue Output 16-Bit (6411 _h).....	84
8.4.3	Write Analogue Output 32-Bit (6412 _h).....	85
8.4.4	Write Analogue Output Float (6413 _h).....	86
8.4.5	Write Manufacturer-specific Analogue Output (6414 _h).....	87
8.5	Analogue input set-ups.....	88
8.5.1	(6420 _h) 88	
8.5.2	Analogue Input Interrupt Trigger Selection (6421 _h).....	89
8.5.3	Analogue Input Interrupt Source (6422 _h).....	90
8.5.4	Analogue Input Global Interrupt Enable (6423 _h).....	91
8.5.5	Analogue Input Interrupt Upper Limit Integer (6424 _h).....	92
8.5.6	Analogue Input Interrupt Lower Limit Integer (6425 _h).....	93
8.5.7	Analogue Input Interrupt Delta Unsigned (6426 _h).....	94
8.5.8	Analogue Input Interrupt Negative Delta Unsigned (6427 _h).....	95
8.5.9	Analogue Input Interrupt Positive Delta Unsigned (6428 _h).....	96
8.5.10	Analogue Input Interrupt Upper Limit Float (6429 _h).....	98
8.5.11	Analogue Input Interrupt Lower Limit Float (642A _h).....	99
8.5.12	Analogue Input Interrupt Delta Float (642B _h).....	100
8.5.13	Analogue Input Interrupt Negative Delta Float (642C _h).....	101
8.5.14	Analogue Input Interrupt Positive Delta Float (642D _h).....	102
8.5.15	Analogue Input Offset Float (642E _h).....	103
8.5.16	Analogue Input Scaling Float (642F _h).....	104
8.5.17	Analogue Input SI Unit (6430 _h).....	105

8.5.18	Analogue Input Offset Integer (6431 _h).....	106
8.5.19	Analogue Input Scaling Integer (6432 _h).....	107
8.6	Analogue output set-ups.....	108
8.6.1	(6440 _h) 108	
8.6.2	Analogue Output Offset Float (6441 _h).....	109
8.6.3	Analogue Output Scaling Float (6442 _h).....	110
8.6.4	Analogue Output Error Mode (6443 _h).....	111
8.6.5	Analogue Output Error Value Integer (6444 _h).....	112
8.6.8	Analogue Output Error Value Float (6445 _h).....	113
8.6.9	Analogue Output Offset Integer (6446 _h).....	114
8.6.10	Analogue Output Scaling Integer (6447 _h).....	115
8.6.11	Analogue Output SI Unit (6450 _h).....	116
8.7	General device profile objects.....	117
8.7.1	Device type (67FF)	117
A1 Pre-defined communication objects for joysticks		118
A1.1	Index 1000 _h (device type)	118
A2 Joystick buttons		118
A3 Joystick proportional inputs.....		118
A4 Joystick PDO mappings		118
A4.1	1st TPDO mapping (buttons)	118
A4.2	2nd TPDO mapping (proportional inputs).....	118
A4.3	Joystick implementation hints.....	119
A4.3.1	Periodical PDO transmission.....	119
A4.3.2	Additional proportional inputs	119
A4.3.3	Transmission of proportional inputs	119

History

This document is based on version 2.0 and includes the corrections already published in the errata sheet. Additional type error corrections and other editorial changes (mostly clarifications and rewordings) are not listed in detail, only changes with technical content are recorded in the following table:

Chapter	Comment
Joystick appendix	Internal freeze function is optionally allowed.

1 Scope

This document represents the CANopen device profiles for generic digital and analogue input and output modules. All these devices use communication techniques, which conform to those described in the CiA DS-301 CANopen Communication Profile. In addition, programmable I/O devices may use communication techniques, which conform to those described in the CiA DSP-302 Framework for programmable CANopen Devices or in the CiA DSP Layer Setting Services (LSS) specification. These specifications should be consulted in parallel to this device profile specification.

In the appendices, some specific I/O devices are defined.

2 Normative references

- /1/: IS 11898, Road vehicles – Interchange of digital information – Controller area network (CAN), November 1993.
- /2/: CiA DS-301 V4.01, CANopen application layer and communication profile, June 2000.
- /3/: CiA DRP-303-2 V1.1, Representation of SI Units and Prefixes, January 2000.
- /4/: CiA DSP-302 V3.0, Framework for programmable CANopen devices, June 2000
- /5/: CiA DSP-305 V1.1, Layer Setting Specification (LSS), January 2001

3 Definitions, acronyms and abbreviations

CAN

Controller Area Network. Data link layer protocol for serial communication as specified in ISO 11898-1 (1999).

CiA

CAN in Automation international users and manufacturers group e.V. Non-profit association promoting Controller Area Network (CAN).

COB

Communication Object, which is made of one or more CAN frames. Any information transmitted via CANopen has to be mapped into COBs.

COB-ID

COB-Identifier. Identifies a COB uniquely in a CAN network. The identifier determines the priority of that COB in the data link layer, too.

I/O

Input and output

RPDO

Receive Process Data Object. Communication object of a device, which contains output data.

SDO

Service Data Object. Peer-to-peer communication with access to the Object Dictionary of a CANopen device.

TPDO

Transmit Process Data Object. Communication object of a device, which contains input data.

4 Operating principle

4.1 Introduction

The purpose of I/O modules is to connect sensors and actuators to CANopen networks. In operational mode, input data can be transmitted from the inputs via TPDOs. By default, the PDO transmission is triggered by an interrupt (event). Optionally PDOs may be transmitted synchronously or remotely requested. In addition, it is possible to read input data via SDO communication from another module, or to write data via SDO to the network, if the module provides SDO client functionality.

Output data can be received via RPDO by those I/O modules that have output capabilities. Output data also can be received via SDO communication services.

However, the main purpose of SDO communication is to configure an I/O module. The module can receive via SDO I/O configuration data, parameters for converting data into meaningful measurements and so on. I/O modules compliant with this device profile use pre-defined PDOs. The default mapping of application objects into TPDO respectively RPDO may be changed via SDO, if variable PDO mapping is supported. An I/O module may provide optionally Sync producer/consumer, Time-Stamp producer/consumer and Emergency producer/consumer functionality. For new designs, it is highly recommended to support Heartbeat functionality.

5 Error handling

5.1 Principle

Emergency messages shall be triggered by internal errors in the device and they are assigned the highest possible priority to ensure that they get access to the bus without latency. By default, the Emergency messages shall contain the error field with pre-defined error numbers and additional information.

5.2 Error behaviour

If a serious device failure is detected the module shall enter by default autonomously the Pre-operational state. If 1029_h object is implemented, the device may be configured to enter alternatively the Stopped state or remain in the current state in case of a device failure. Device failures should include the following communication errors:

- Bus-off conditions of the CAN interface
- Life guarding event with the state 'occurred'
- Heartbeat event with state 'occurred'

Severe device errors also may be caused by device internal failures.

5.3 Additional error code meanings

Error Code	Meaning
2310 _h	Current at outputs too high (overload)
2320 _h	Short circuit at outputs
2330 _h	Load dump at outputs
3110 _h	Input voltage too high
3120 _h	Input voltage too low
3210 _h	Internal voltage too high
3220 _h	Internal voltage too low
3310 _h	Output voltage too high
3320 _h	Output voltage too low

6 Pre-definitions

6.1 Introduction

If a device supports a specific type of I/O functionality (analogue/digital I/O) it shall support the related default PDOs. However, the module may support additional manufacturer-specific PDOs. If variable PDO mapping is supported the PDO default settings may be changed by means of configuration.

There shall be up to 4 enabled TPDOs and up to 4 enabled RPDOs with default mappings. If a module does not support a specific I/O function, the related default PDOs shall remain unused. If a device supports more than the default digital input or output channels, the related analogue default PDOs shall remain unused and the additional digital I/Os may use additional PDOs. This shall be the same for additional analogue channels. All TPDOs with transmission type 255 shall be transmitted when entering the Operational state.

6.2 Pre-defined communication objects

Modules compliant with this device profile shall come with default values for some communication objects (1000_h to 1FFF_h), which are not specified in all details in /2/.

6.2.1 Device type (1000_h)

The object at index 1000_h describes the type of device and its functionality. For multiple device modules the Additional information parameter shall contain FFFF_h. In this case, the 67FF_h object shall be implemented.

Additional information		General information	
Specific functionality	I/O functionality	Device profile number	
31	24 23	16 15	0
MSB			LSB

General information

Device profile number: 401d

Additional information

1 = function is implemented
 0 = function is not implemented

I/O functionality:

- 16th Bit: Digital input
- 17th Bit: Digital output
- 18th Bit: Analogue input
- 19th Bit: Analogue output
- Rest: Reserved

Any combination of digital/analogue, inputs and outputs is allowed.

Specific functionality:

Code	Function	Reference
0 _h	No specific function	-
1 _h	Joystick	Appendix A
2 _h ..FF _h	Reserved	-

6.2.2 Error Register (1001_h)

The device-specific bit in the status byte is reserved for future use.

6.2.3 Error Behaviour (1029_h)

The object specifies to which state an I/O module shall be set, when a communication error, output error or input error is detected.

0 = Pre-operational (only if the current state is Operational)

1 = no state change

2 = Stopped

In addition to the specification in /2/ the following sub-indices may be implemented.

Sub-Index	2 _h
Description	Output Error
Access	rw
Entry Category	Optional
PDO Mapping	No
Value Range	0 _h to 2 _h
Default Value	0 _h

Sub-Index	3 _h
Description	Input Error
Access	rw
Entry Category	Optional
PDO Mapping	No
Value Range	0 _h to 2 _h
Default Value	0 _h

Note: If the 1029_h object is not implemented the device shall be set into the Pre-operational state in the case a communication error is detected.

6.2.4 1st RPDO mapping (digital outputs)

This RPDO receives asynchronously the values of maximum 64 digital outputs to I/O module. The default transmission type shall be 255. *Note:* After power-on and application reset the values of the mapped outputs are as the default values or the stored values after configuration (stored values overwrites default values).

Receive PDO Communication Parameter

Index	Sub-Index	Comment	Default Value
1400 _h	0 _h	Largest sub-index supported	No
	1 _h	COB-ID used by PDO	See /1/
	2 _h	Transmission type	255
	3 _h	Inhibit time	No
	4 _h	reserved	See /1/
	5 _h	Event timer	No

Receive PDO Mapping Parameter

Index	Sub-Index	Comment	Default Value
1600 _h	0 _h	number of mapped objects	No
	1 _h	Write Output 1 _h to 8 _h	6200 01 08 _h
	2 _h	Write Output 9 _h to 10 _h	6200 02 08 _h
	3 _h	Write Output 11 _h to 18 _h	6200 03 08 _h
	4 _h	Write Output 19 _h to 20 _h	6200 04 08 _h
	5 _h	Write Output 21 _h to 28 _h	6200 05 08 _h
	6 _h	Write Output 29 _h to 30 _h	6200 06 08 _h
	7 _h	Write Output 31 _h to 38 _h	6200 07 08 _h
	8 _h	Write Output 39 _h to 40 _h	6200 08 08 _h

The number of mapped objects into the PDO depends on the hardware.

6.2.5 1st TPDO mapping (digital inputs)

This TPDO transmits event-driven the values of maximum 64 digital inputs. The default transmission type shall be 255; the default values for inhibit and event timer shall be 0. If one digital input changes its value, this PDO shall be transmitted immediately. If an interrupt mask is enabled, the PDO shall be transmitted only if the interrupt condition is fulfilled.

Transmit PDO Communication Parameter

Index	Sub-Index	Comment	Default Value
1800 _h	0 _h	Largest sub-index supported	No
	1 _h	COB-ID used by PDO	See /1/
	2 _h	Transmission type	255
	3 _h	Inhibit time	0
	4 _h	reserved	See /1/
	5 _h	Event timer	0

Transmit PDO Mapping Parameter

Index	Sub-Index	Comment	Default Value
1A00 _h	0 _h	number of mapped objects	No
	1 _h	Read Input 1 _h to 8 _h	6000 01 08 _h
	2 _h	Read Input 9 _h to 10 _h	6000 02 08 _h
	3 _h	Read Input 11 _h to 18 _h	6000 03 08 _h
	4 _h	Read Input 19 _h to 20 _h	6000 04 08 _h
	5 _h	Read Input 21 _h to 28 _h	6000 05 08 _h
	6 _h	Read Input 29 _h to 30 _h	6000 06 08 _h
	7 _h	Read Input 31 _h to 38 _h	6000 07 08 _h
	8 _h	Read Input 39 _h to 40 _h	6000 08 08 _h

The number of mapped objects into the PDO depends on the hardware.

6.2.6 2nd RPDO mapping (analogue outputs)

This RPDO receives asynchronously the 16-bit values of maximum 4 analogue outputs to the module. The default transmission type shall be 255. *Note:* After power-on and application reset the values of the mapped outputs are as the default values or the stored values after configuration (stored values overwrites default values).

Receive PDO Communication Parameter

Index	Sub-Index	Comment	Default Value
1401 _h	0 _h	Largest sub-index supported	No
	1 _h	COB-ID used by PDO	See /1/
	2 _h	Transmission type	255
	3 _h	Inhibit time	No
	4 _h	reserved	See /1/
	5 _h	Event timer	No

Receive PDO Mapping Parameter

Index	Sub-Index	Comment	Default Value
1601 _h	0 _h	number of mapped objects	No
	1 _h	Write Analogue Output 1 _h	6411 01 10 _h
	2 _h	Write Analogue Output 2 _h	6411 02 10 _h
	3 _h	Write Analogue Output 3 _h	6411 03 10 _h
	4 _h	Write Analogue Output 4 _h	6411 04 10 _h

The number of mapped objects into the PDO depends on the hardware.

6.2.7 2nd TPDO mapping (analogue inputs)

This TPDO transmits event-driven the 16-bit values of maximum 4 analogue inputs. The default transmission type shall be 255; the default values for inhibit and event timer shall be 0. By default the interrupt source (6423_h object) shall be disabled. If one analogue input changes its value and 6423_h object is enabled, the PDO shall be transmitted immediately. If an analogue interrupt condition is enabled, the PDO shall be transmitted only if this interrupt condition is fulfilled. If more than one interrupt condition is enabled; the PDO shall be transmitted if one of these conditions is fulfilled.

Transmit PDO Communication Parameter

Index	Sub-Index	Comment	Default Value
1801 _h	0 _h	Largest sub-index supported	No
	1 _h	COB-ID used by PDO	See /1/
	2 _h	Transmission type	255
	3 _h	Inhibit time	0
	4 _h	reserved	See /1/
	5 _h	Event timer	0

Transmit PDO Mapping Parameter

Index	Sub-Index	Comment	Default Value
1A01 _h	0 _h	number of mapped objects	No
	1 _h	Read Analogue Output 1 _h	6401 01 10 _h
	2 _h	Read Analogue Output 2 _h	6401 02 10 _h
	3 _h	Read Analogue Output 3 _h	6401 03 10 _h
	4 _h	Read Analogue Output 4 _h	6401 04 10 _h

The number of mapped objects into the PDO depends on the hardware.

6.2.8 3rd RPDO mapping (analogue outputs)

This RPDO receives asynchronously the 16-bit values of maximum 4 analogue outputs to the module. The default transmission type shall be 255. *Note:* After power-on and application reset the values of the mapped outputs are as the default values or the stored values after configuration (stored values overwrites default values).

Receive PDO Communication Parameter

Index	Sub-Index	Comment	Default Value
1402 _h	0 _h	Largest sub-index supported	No
	1 _h	COB-ID used by PDO	See /1/
	2 _h	Transmission type	255
	3 _h	Inhibit time	No
	4 _h	reserved	See /1/
	5 _h	Event timer	No

Receive PDO Mapping Parameter

Index	Sub-Index	Comment	Default Value
1602 _h	0 _h	number of mapped objects	No
	1 _h	Write Analogue Output 5 _h	6411 05 10 _h
	2 _h	Write Analogue Output 6 _h	6411 06 10 _h
	3 _h	Write Analogue Output 7 _h	6411 07 10 _h
	4 _h	Write Analogue Output 8 _h	6411 08 10 _h

The number of mapped objects into the PDO depends on the hardware.

6.2.9 3rd TPDO mapping (analogue inputs)

This TPDO transmits event-driven the 16-bit values of maximum 4 analogue inputs. The default transmission type shall be 255; the default values for inhibit and event timer shall be 0. By default the interrupt source (6423_h object) shall be disabled. If one analogue input changes its value and 6423_h object is enabled, the PDO shall be transmitted immediately. If an analogue interrupt condition is enabled; the PDO shall be transmitted only if this interrupt condition is fulfilled. If more than one interrupt condition is enabled; the PDO shall be transmitted if one of these conditions is fulfilled.

Transmit PDO Communication Parameter

Index	Sub-Index	Comment	Default Value
1802 _h	0 _h	Largest sub-index supported	No
	1 _h	COB-ID used by PDO	See /1/
	2 _h	Transmission type	255
	3 _h	Inhibit time	0
	4 _h	reserved	See /1/
	5 _h	Event timer	0

Transmit PDO Mapping Parameter

Index	Sub-Index	Comment	Default Value
1A02 _h	0 _h	number of mapped objects	No
	1 _h	Read Analogue Output 5 _h	6401 05 10 _h
	2 _h	Read Analogue Output 6 _h	6401 06 10 _h
	3 _h	Read Analogue Output 7 _h	6401 07 10 _h
	4 _h	Read Analogue Output 8 _h	6401 08 10 _h

The number of mapped objects into the PDO depends on the hardware.

6.2.10 4th RPDO mapping (analogue outputs)

This RPDO receives asynchronously the 16-bit values of maximum 4 analogue outputs to the module. The default transmission type shall be 255. *Note:* After power-on and application reset the values of the mapped outputs are as the default values or the stored values after configuration (stored values overwrites default values).

Receive PDO Communication Parameter

Index	Sub-Index	Comment	Default Value
1403 _h	0 _h	Largest sub-index supported	No
	1 _h	COB-ID used by PDO	See /1/
	2 _h	Transmission type	255
	3 _h	Inhibit time	No
	4 _h	reserved	See /1/
	5 _h	Event timer	No

Receive PDO Mapping Parameter

Index	Sub-Index	Comment	Default Value
1603 _h	0 _h	number of mapped objects	No
	1 _h	Read Analogue Output 9 _h	6411 09 10 _h
	2 _h	Read Analogue Output A _h	6411 0A 10 _h
	3 _h	Read Analogue Output B _h	6411 0B 10 _h
	4 _h	Read Analogue Output C _h	6411 0C 10 _h

The number of mapped objects into the PDO depends on the hardware.

6.2.11 4th TPDO mapping (analogue inputs)

This TPDO transmits event-driven the 16-bit values of maximum 4 analogue inputs. The default transmission type shall be 255; the default values for inhibit and event timer shall be 0. By default the interrupt source (6423_h object) shall be disabled. If one analogue input changes its value and 6423_h object is enabled, the PDO shall be transmitted immediately. If an analogue interrupt condition is enabled; the PDO shall be transmitted only if this interrupt condition is fulfilled. If more than one interrupt condition is enabled; the PDO shall be transmitted if one of these conditions is fulfilled.

Receive PDO Communication Parameter

Index	Sub-Index	Comment	Default Value
1803 _h	0 _h	Largest sub-index supported	No
	1 _h	COB-ID used by PDO	See /1/
	2 _h	Transmission type	255
	3 _h	Inhibit time	0
	4 _h	reserved	See /1/
	5 _h	Event timer	0

Receive PDO Mapping Parameter

Index	Sub-Index	Comment	Default Value
1A03 _h	0 _h	number of mapped objects	No
	1 _h	Write Analogue Output 9 _h	6401 09 10 _h
	2 _h	Write Analogue Output A _h	6401 0A 10 _h
	3 _h	Write Analogue Output B _h	6401 0B 10 _h
	4 _h	Write Analogue Output C _h	6401 0C 10 _h

The number of mapped objects into the PDO depends on the hardware.

7 Object dictionary

Each I/O module compliant with this device profile shall share the CANopen Object Dictionary entries from 6000_h to 67FF_h. These entries are common to all I/O modules and each module only implements those objects relevant to its functions. Object Description and Entry Description are specified in /2/.

7.1 Input and output function principles

7.1.1 Object dictionary for the digital input and output modules

Command sequence

It is possible to switch the modules output or input polarity. This feature is the one which is nearest to the sensors and actuators, e.g. if the polarity of an output is enabled and the output is set to high, then the output level is '0'.

The following table shows the profile command sequence.

Commands	Polarity switch	Process
Read input	enabled: 0 change to 1	Sensor or actuator
Write output	1 change to 0	
Interrupt mask	disabled: 0 remains 0	
Error mode	1 remains 1	

Example of the polarity with a digital output:

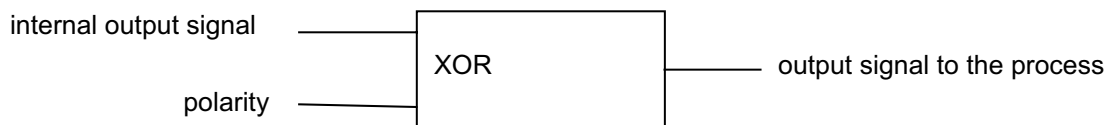

Access to 1-, 8-, 16- and 32-points

There are different objects to allow 1-bit, 8-bit, 16-bit or 32-bit access to digital inputs or outputs (e.g. definition of polarity). If these objects define the same function, they access single database. Example: If the 6002_h object (Change Polarity Input 8-bit) Sub-index 1_h has the value AA_h and Sub-index 2_h the value 0F_h, 6102_h object (Change Polarity Input 16-bit) Sub-index 1_h shall have the value 0FAA_h.

I/O channel to Sub-index relation

The bit position is defined by the following formula:

$$\text{Bit position} = (\text{I/O channel no.} - 1) \text{ MOD } (\text{length of data type})$$

The sub-index, where a bit is located, is calculated by the following formula:

$$\text{Sub-index} = (\text{I/O channel no.} - 1) \text{ DIV } (\text{length of data type}) + 1$$

Example 8-bit access:

Sub-index 1

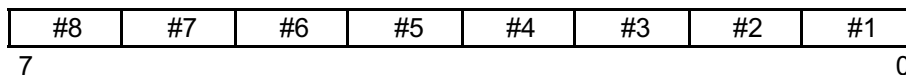

Sub-index 2

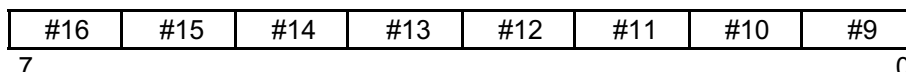

7.1.2 Digital input module

There are different access methods defined. By default, 8-bit access shall be supported; the other access methods are optional. The tables list the digital input objects.

The following table lists the objects for 8-bit access.

Index	Object Code (OC)	Name	Data Type	Category
6000 _h	Array	Read Input 8-bit	Unsigned8	C: DI
6001 _h	-	Reserved	-	-
6002 _h	Array	Polarity Input 8-bit	Unsigned8	O
6003 _h	Array	Filter Constant Input 8-bit	Unsigned8	O
6004 _h	-	Reserved	-	-
6005 _h	Var	Global Interrupt Enable Digital	Boolean	O
6006 _h	Array	Interrupt Mask Any Change 8-bit	Unsigned8	O
6007 _h	Array	Interrupt Mask Low-to-High 8-bit	Unsigned8	O
6008 _h	Array	Interrupt Mask High-to-Low 8-bit	Unsigned8	O
6009 _h	-	Reserved	-	-
to				
601E _h	-	Reserved	-	-

The figure shows the relationship between the digital input objects for an 8-bit access.

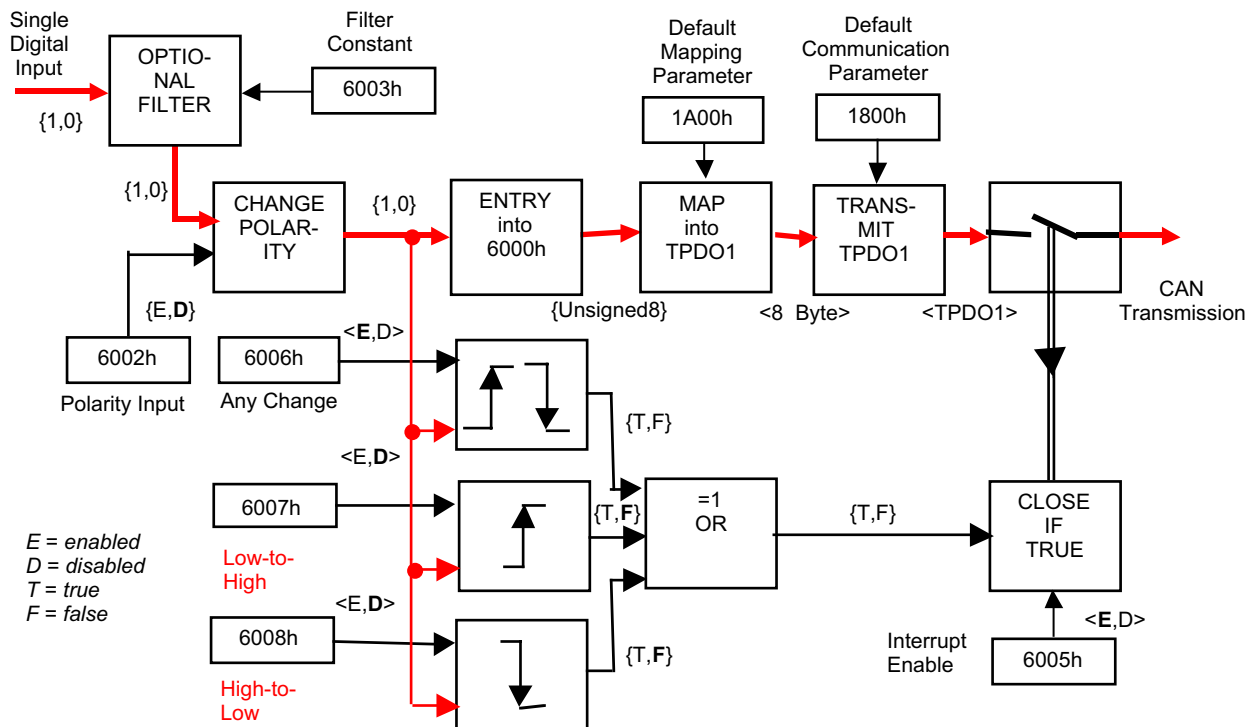

The following table lists the objects for 1-bit, 16-bit and 32-bit access.

Index	OC	Name	Data Type	Category
601F _h	-	Reserved	-	-
6020 _h	Array	Read Input Bit 1 to 128	Boolean	O
to				
6027 _h	Array	Read Input Bit 897 to 1024	Boolean	O
6028 _h	-	Reserved	-	-
to				
602F _h	-	Reserved	-	-
6030 _h	Array	Polarity Input Bit 1 to 128	Boolean	O
to				
6037 _h	Array	Polarity Input Bit 897 to 1024	Boolean	O
6038 _h	Array	Filter Constant Input Bit 1 to 128	Boolean	O
to				
603F _h	Array	Filter Constant Input Bit 897 to 1024	Boolean	O
604F _h	-	Reserved	-	-
6050 _h	Array	Interrupt Mask Input Bit 1 to 128 Any Change	Boolean	O
to				
6057 _h	Array	Interrupt Mask Input Bit 897 to 1024 Any Change	Boolean	O
6058 _h	-	Reserved	-	-
to				
605F _h	-	Reserved	-	-
6060 _h	Array	Interrupt Mask Input Bit 1 to 128 Low-to-High	Boolean	O
to				
6067 _h	Array	Interrupt Mask Input Bit 897 to 1024 Low-to-High	Boolean	O
6068 _h	-	Reserved	-	-
to				
606F _h	-	Reserved	-	-
6070 _h	Array	Interrupt Mask Input Bit 1 to 128 High-to-Low	Boolean	O
to				
6077 _h	Array	Interrupt Mask Input Bit 897 to 1024 High-to-Low	Boolean	O
6078 _h	-	Reserved	-	-
to				
60FF _h	-	Reserved	-	-
6100 _h	Array	Read Input 16-Bit	Unsigned16	O
6101 _h	-	Reserved	-	-
6102 _h	Array	Polarity Input 16-Bit	Unsigned16	O
6103 _h	Array	Filter Constant Input 16-Bit	Unsigned16	O
6104 _h	-	Reserved	-	-
6105 _h	-	Reserved	-	-
6106 _h	Array	Interrupt Mask Input 16-Bit Any Change	Unsigned16	O
6107 _h	Array	Interrupt Mask Input 16-Bit Low-to-High	Unsigned16	O
6108 _h	Array	Interrupt Mask Input 16-Bit High-to-Low	Unsigned16	O
6109 _h	-	Reserved	-	-
to				
611F _h	-	Reserved	-	-
6120 _h	Array	Read Input 32-Bit	Unsigned32	O
6121 _h	-	Reserved	-	-
6122 _h	Array	Polarity Input 32-Bit	Unsigned32	O
6123 _h	Array	Filter Constant Input 32-Bit	Unsigned32	-
6124 _h	-	Reserved	-	-
6125 _h	-	Reserved	-	-
6126 _h	Array	Interrupt Mask Input 32-Bit Any Change	Unsigned32	O
6127 _h	Array	Interrupt Mask Input 32-Bit Low-to-High	Unsigned32	O
6128 _h	Array	Interrupt Mask Input 32-Bit High-to-Low	Unsigned32	O
6129 _h	-	Reserved	-	-
to				
61FF _h	-	Reserved	-	-

7.1.3 Digital output module

There are different access methods defined. By default, 8-bit access shall be supported; the other access methods are optional. The tables list the digital output objects.

The following table lists the objects for 8-bit access.

Index	Object Code (OC)	Name	Data Type	Category
6200 _h	Array	Write Output 8-Bit	Unsigned8	C: DO
6201 _h	-	Reserved	-	-
6202 _h	Array	Change Polarity Output 8-Bit	Unsigned8	O
6203 _h		Reserved	-	-
to				
6205 _h	-	Reserved	-	-
6206 _h	Array	Error Mode Output 8-Bit	Unsigned8	O
6207 _h	Array	Error Value Output 8-Bit	Unsigned8	O
6208 _h	Array	Filter Constant Output 8-Bit	Unsigned8	O
6209 _h	-	Reserved	-	-
to				
621E _h	-	Reserved	-	-

The figure shows the relationship between the digital output objects for an 8-bit access.

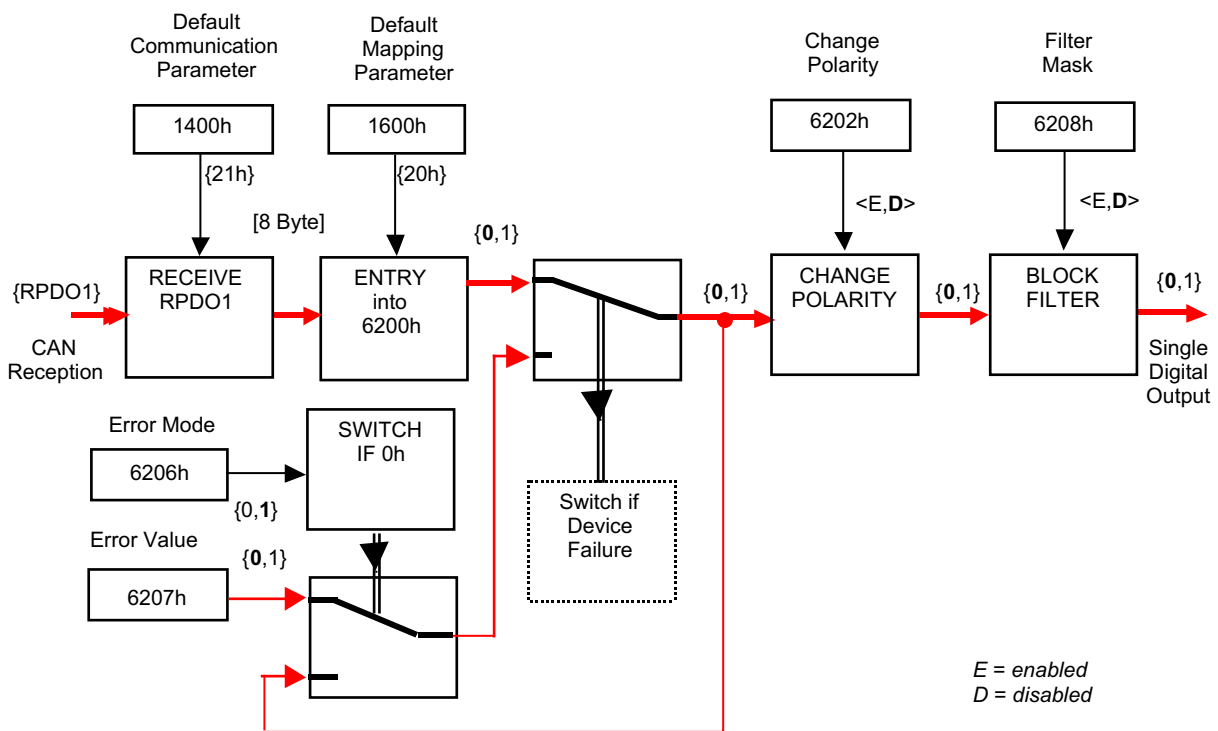

The following table lists the objects for 1-, 16- and 32-Bit access.

Index	OC	Name	Data Type	Category
621F _h	-	Reserved	-	-
6220 _h	Array	Write Output Bit 1 to 128	Boolean	O
		to		
6227 _h	Array	Write Output Bit 897 to 1024	Boolean	O
6228 _h	-	Reserved	-	-
		to		
623F _h	-	Reserved	-	-
6240 _h	Array	Change Polarity Output Bit 1 to 128	Boolean	O
		to		
6247 _h	Array	Change Polarity Output Bit 897 to 1024	Boolean	O
6248 _h	-	Reserved	-	-
		to		
624F _h	-	Reserved	-	-
6250 _h	Array	Error Mode Output Bit 1 to 128	Boolean	O
		to		
6257 _h	Array	Error Mode Output Bit 897 to 1024	Boolean	O
6258 _h	-	reserved	-	-
		to		
625F _h	-	reserved	-	-
6260 _h	Array	Error Value Output Bit 1 to 128	Boolean	O
		to		
6267 _h	Array	Error Value Output Bit 897 to 1024	Boolean	O
6268 _h	-	Reserved	-	-
		to		
626F _h	-	Reserved	-	-
6270 _h	Array	Filter Constant Output Bit 1 to 128	Boolean	O
		to		
6277 _h	Array	Filter Constant Output Bit 897 to 1024	Boolean	O
6278 _h	-	Reserved	-	-
		to		
62FF _h	-	Reserved	-	-
6300 _h	Array	Write Output 16-Bit	Unsigned16	O
6301 _h	-	Reserved	-	-
6302 _h	Array	Change Polarity Output 16-Bit	Unsigned16	O
6303 _h	-	Reserved	-	-
		to		
6305 _h	-	Reserved	-	-
6306 _h	Array	Error Mode Output 16-Bit	Unsigned16	O
6307 _h	Array	Error Value Output 16-Bit	Unsigned16	O
6308 _h	Array	Filter Constant Output 16-Bit	Unsigned16	O
6309 _h	-	Reserved	-	-
		to		
631F _h	-	Reserved	-	-
6320 _h	Array	Write Output 32-Bit	Unsigned32	O
6321 _h	-	Reserved	-	-
6322 _h	Array	Change Polarity Output 32-Bit	Unsigned32	O
6323 _h	-	Reserved	-	-
		to		
6325 _h	-	Reserved	-	-
6326 _h	Array	Error Mode Output 32-Bit	Unsigned32	O
6327 _h	Array	Error Value Output 32-Bit	Unsigned32	O
6328 _h	Array	Filter Constant Output 32-Bit	Unsigned32	O
6329 _h	-	Reserved	-	-
		to		
63FF _h	-	Reserved	-	-

7.1.4 Analogue input module

There are different access methods defined. By default, 16-bit access shall be supported; the other access methods are optional.

Index	Object Code	Name	Data Type	Category
6400 _h	Array	Read Analogue Input 8-Bit	Integer8	O
6401 _h	Array	Read Analogue Input 16-Bit	Integer16	C: AI
6402 _h	Array	Read Analogue Input 32-Bit	Integer32	O
6403 _h	Array	Read Analogue Input Float	Float	O
6404 _h	Array	Read Manufacturer-specific Analogue Input	specific	O

The figure shows the relationship between the analogue input objects for an Integer16 access.

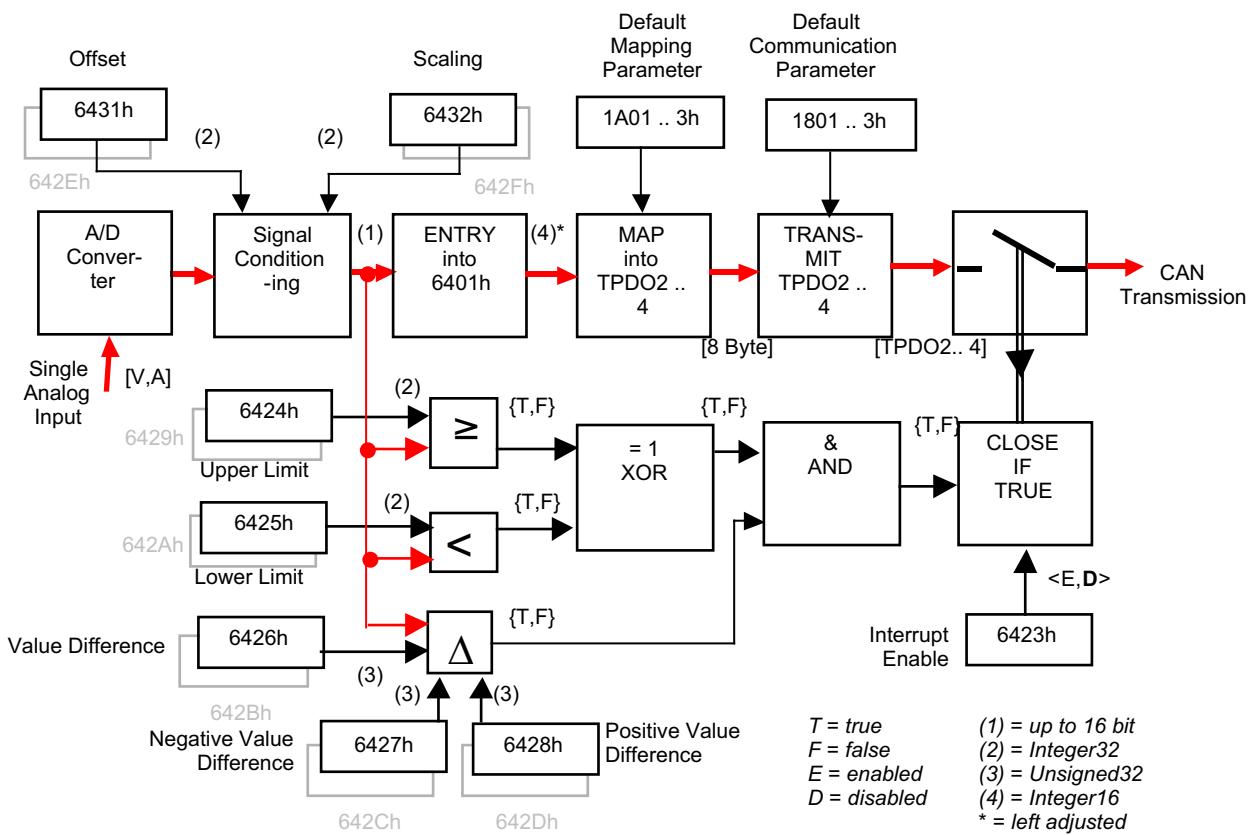

7.1.5. Analogue output module

There are different access methods defined. By default, 16-bit access shall be supported; the other access methods are optional.

Index	Object Code	Name	Data Type	Category
6410 _h	Array	Write Analogue Output 8-Bit	Integer8	O
6411 _h	Array	Write Analogue Output 16-Bit	Integer16	C:AO
6412 _h	Array	Write Analogue Output 32-Bit	Integer32	O
6413 _h	Array	Write Analogue Output Float	Float	O
6414 _h	Array	Write Manufacturer-specific Analogue Output	specific	O

The figure shows the relationship between the analogue output objects for an Integer16 access.

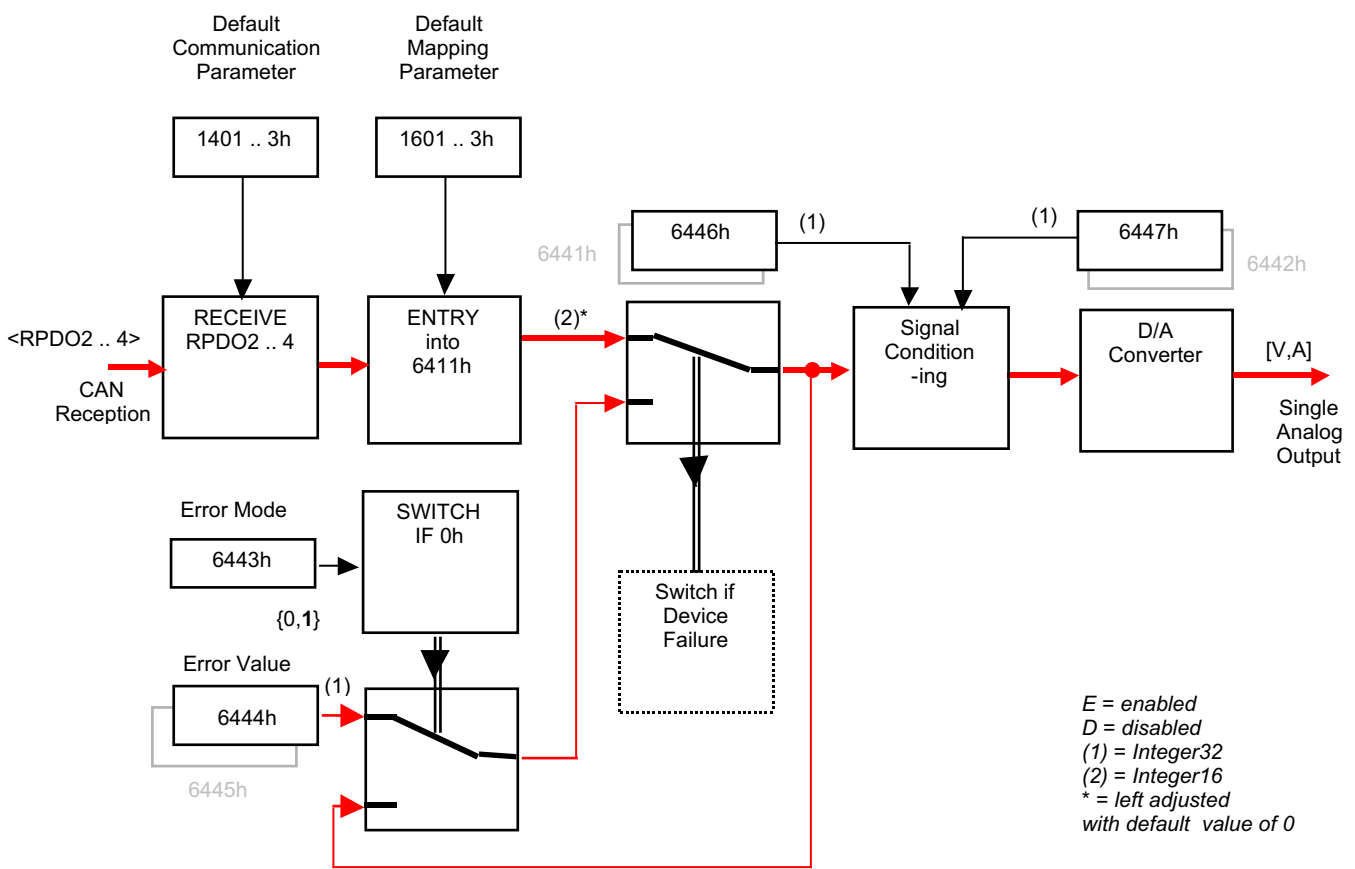

7.1.6 Analogue input set-ups

Index	Object Code	Name	Data Type	Category
6420 _h	-	Reserved for compatibility reason	-	-
6421 _h	Array	Analogue Input Interrupt Trigger Selection	Unsigned8	0
6422 _h	Array	Analogue Input Interrupt Source	Unsigned32	0
6423 _h	Var	Analogue Input Global Interrupt Enable	Boolean	C: AI
6424 _h	Array	Analogue Input Interrupt Upper Limit Integer	Integer32	0
6425 _h	Array	Analogue Input Interrupt Lower Limit Integer	Integer32	0
6426 _h	Array	Analogue Input Interrupt Delta Unsigned	Unsigned32	0
6427 _h	Array	Analogue Input Interrupt Negative Delta Unsigned	Unsigned32	0
6428 _h	Array	Analogue Input Interrupt Positive Delta Unsigned	Unsigned32	0
6429 _h	Array	Analogue Input Interrupt Upper Limit Float	Float	0
642A _h	Array	Analogue Input Interrupt Lower Limit Float	Float	0
642B _h	Array	Analogue Input Interrupt Delta Float	Float	0
642C _h	Array	Analogue Input Interrupt Negative Delta Float	Float	0
642D _h	Array	Analogue Input Interrupt Positive Delta Float	Float	0
642E _h	Array	Analogue Input Offset Float	Float	0
642F _h	Array	Analogue Input Scaling Float	Float	0
6430 _h	Array	Analogue Input SI Unit	Unsigned32	0
6431 _h	Array	Analogue Input Offset Integer	Integer32	0
6432 _h	Array	Analogue Input Scaling Integer	Integer32	0
6433 _h	-	Reserved	-	-
to				
673F _h	-	Reserved	-	-

7.1.7 Analogue output set-ups

Index	Object Code	Name	Data Type	Category
6440 _h	-	Reserved for compatibility reason	-	-
6441 _h	Array	Analogue Output Offset Float	Float	0
6442 _h	Array	Analogue Output Scaling Float	Float	0
6443 _h	Array	Analogue Output Error Mode	Unsigned8	0
6444 _h	Array	Analogue Output Error Value Integer	Integer32	0
6445 _h	Array	Analogue Output Error Value Float	Float	0
6446 _h	Array	Analogue Output Offset Integer	Integer32	0
6447 _h	Array	Analogue Output Scaling Integer	Integer32	0
6448 _h	-	Reserved	-	-
to				
644F _h	-	Reserved	-	-
6450 _h	Array	Analogue Output SI Unit	Unsigned32	0
6451 _h	-	Reserved	-	-
to				
67FD _h	-	Reserved	-	-

7.1.8 General device profile objects

Index	Object Code	Name	Data Type	Category
67FF _h	Var	Device Type (see /2/)	Unsigned32	0

8 Object descriptions

8.1 Digital input module

8.1.1 Read Input 8-Bit (6000h)

This object shall read groups of 8 input lines as 8-bit information. A maximum of 254 x 8-Bit inputs is addressable (2032 inputs). This object is mandatory for digital input modules and shall support all implemented input lines.

Object Description

INDEX	6000 _h
Name	Read Input 8 Bit
Object Code	Array
Data Type	Unsigned8
Category	Conditional: Device with digital inputs

Entry Description

Sub-Index	0 _h
Description	Number of Inputs 8-Bit
Access	ro
Entry Category	Mandatory
PDO Mapping	No
Value Range	1 _h to FE _h
Default Value	No

Sub-Index	1 _h
Description	Read Input 1 _h to 8 _h
Access	ro
Entry Category	Mandatory
PDO Mapping	Default
Value Range	Unsigned8
Default Value	No

Sub-Index	2 _h
Description	Read Input 9 _h to 10 _h
Access	ro
Entry Category	Optional
PDO Mapping	Default
Value Range	Unsigned8
Default Value	No

to

Sub-Index	8 _h
Description	Read Input 39 _h to 40 _h
Access	ro
Entry Category	Optional
PDO Mapping	Default
Value Range	Unsigned8
Default Value	No

Sub-Index	9 _h
Description	Read Input 41 _h to 48 _h
Access	ro
Entry Category	Optional
PDO Mapping	Optional
Value Range	Unsigned8
Default value	No

to

Sub-Index	Fe _h
Description	Read Input 7E8 _h to 7F0 _h
Access	ro
Entry Category	Optional
PDO Mapping	Optional
Value Range	Unsigned8
Default value	No

8.1.2 Polarity Input 8-Bit (6002_h)

This object shall define the polarity of a group of 8 input lines. Input polarity can be inverted individually.

1 = input inverted

0 = input not inverted

If the object is not supported the device shall behave accordingly to the default value.

Object Description

INDEX	6002 _h
Name	Polarity Input 8-Bit
Object Code	Array
Data Type	Unsigned8
Category	Optional

Entry Description

Sub-Index	0 _h
Description	Number of Inputs 8-Bit
Access	ro
Entry Category	Mandatory
PDO Mapping	No
Value Range	1 _h to FE _h
Default Value	No

Sub-Index	1 _h
Description	Polarity Input 1 _h to 8 _h
Access	rw
Entry Category	Mandatory
PDO Mapping	Possible
Value Range	Unsigned8
Default Value	0 _h

Sub-Index	2 _h
Description	Polarity Input 9 _h to 10 _h
Access	rw
Entry Category	Optional
PDO Mapping	Possible
Value Range	Unsigned8
Default Value	0 _h

to

Sub-Index	FE _h
Description	Polarity Input 7E8 _h to 7F0 _h
Access	rw
Entry Category	Optional
PDO Mapping	Optional
Value Range	Unsigned8
Default Value	0 _h

8.1.3 Filter Constant Input 8-Bit (6003_h)

This object shall enable and disable an additional configurable filter constant. If the object is not supported, the device shall behave accordingly to the default value. The type of the filter constant and the configuration of the filter constant are manufacturer-specific.

1 = enabled

0 = disabled

Object Description

INDEX	6003 _h
Name	Filter Constant Input 8-Bit
Object Code	Array
Data Type	Unsigned8
Category	Optional

Entry Description

Sub-Index	0 _h
Description	Number of Inputs 8-Bit
Access	ro
Entry Category	Mandatory
PDO Mapping	No
Value Range	1 _h to FE _h
Default Value	No

Sub-Index	1 _h
Description	Filter Constant Input 1 _h to 8 _h
Access	rw
Entry Category	Mandatory
PDO Mapping	Optional
Value Range	Unsigned8
Default Value	0 _h

Sub-Index	2 _h
Description	Filter Constant Input 9 _h to 10 _h
Access	rw
Entry Category	Optional
PDO Mapping	Optional
Value Range	Unsigned8
Default Value	0 _h

to

Sub-Index	FE _h
Description	Filter Constant Input 7E8 _h to 7F0 _h
Access	rw
Entry Category	Optional
PDO Mapping	Optional
Value Range	Unsigned8
Default Value	0 _h

8.1.4 Global Interrupt Enable Digital 8-Bit (6005_h)

This object shall enable and disable globally the interrupt behaviour without changing the interrupt masks. In event-driven mode the device transmits the input values depending on the interrupt masks in objects 6006_h, 6007_h, and 6008 (resp. 6050_h .. 6057_h, 6060_h .. 6067_h, 6070_h .. 6077_h, or 6106_h, 6107_h, 6108_h, or 6126_h, 6127_h) and the PDO transmission type. If the object is not supported, the device shall behave accordingly to the default value.

TRUE = global interrupt enabled

FALSE = global interrupt disabled

Object Description

INDEX	6005 _h
Name	Global Interrupt Enable Digital 8-Bit
Object Code	Variable
Data Type	Boolean
Category	Optional

Entry Description

Sub-Index	0 _h
Access	rw
PDO Mapping	No
Value Range	Boolean
Default Value	TRUE

8.1.5 Interrupt Mask Any Change 8-Bit (6006_h)

This object determines, which input port lines shall activate an interrupt by positive or/and negative edge detection.

1 = interrupt enabled

0 = interrupt disabled

If the object is not supported the device shall behave accordingly to the default value.

Object Description

INDEX	6006 _g
Name	Interrupt Mask Any Change 8-Bit
Object Code	Array
Data Type	Unsigned8
Category	Optional

Entry Description

Sub-Index	0 _h
Description	Number of Inputs 8-Bit
Access	ro
Entry Category	Mandatory
PDO Mapping	No
Value Range	1 _h to FE _h
Default Value	No

Sub-Index	1 _h
Description	Interrupt Any Change 1 _h to 8 _h
Access	rw
Entry Category	Mandatory
PDO Mapping	Optional
Value Range	Unsigned8
Default Value	FF _h

Sub-Index	2 _h
Description	Interrupt Any Change 9 _h to 10 _h
Access	rw
Entry Category	Optional
PDO Mapping	Optional
Value Range	Unsigned8
Default Value	FF _h

to

Sub-Index	FE _h
Description	Interrupt Any Change 7E8 _h to 7F0 _h
Access	rw
Entry Category	Optional
PDO Mapping	Optional
Value Range	Unsigned8
Default Value	FF _h

8.1.6 Interrupt Mask Low-to-High 8-Bit (6007_h)

This object determines, which input port lines shall activate an interrupt by positive edge detection (logical 0 to 1). Done for groups of 8 lines. The values shall be in an "OR" connection to the values of 6006_h object (Interrupt Mask Any Change 8-Bit). If inputs are inverted by 6002_h object (Polarity Input 8-Bit), the positive logical edge shall correspond to negative physical edge.

1 = interrupt enabled

0 = interrupt disabled

Object Description

INDEX	6007 _h
Name	Interrupt Mask Low to High 8-Bit
Object Code	Array
Data Type	Unsigned8
Category	Optional

Entry Description

Sub-Index	0 _h
Description	Number of Inputs 8-Bit
Access	ro
Entry Category	Mandatory
PDO Mapping	No
Value Range	1 _h to FE _h
Default Value	No

Sub-Index	1 _h
Description	Interrupt Low to High 1 _h to 8 _h
Access	rw
Entry Category	Mandatory
PDO Mapping	Optional
Value Range	Unsigned8
Default Value	0 _h

Sub-Index	2 _h
Description	Interrupt Low to High 9 _h to 10 _h
Access	rw
Entry Category	Optional
PDO Mapping	Optional
Value Range	Unsigned8
Default Value	0 _h

to

Sub-Index	FE _h
Description	Interrupt Low to High 7E8 _h to 7F0 _h
Access	rw
Entry Category	Optional
PDO Mapping	Optional
Value Range	Unsigned8
Default Value	0 _h

8.1.7 Interrupt Mask High-to-Low 8-Bit (6008_h)

This object determines, which input port lines shall activate an interrupt by negative edge detection (logical 1 to 0). Done for groups of 8 lines. The values shall be in an "OR" connection to the values of 6006_h object (Interrupt Mask Any Change 8-Bit). If inputs are inverted by 6002_h object (Polarity Input 8-Bit), the negative logical edge shall correspond to positive physical edge.

1 = interrupt enabled

0 = interrupt disabled

Object Description

INDEX	6008 _h
Name	Interrupt Mask High to Low 8-Bit
Object Code	Array
Data Type	Unsigned8
Category	Optional

Entry Description

Sub-Index	0 _h
Description	Number of Inputs 8-Bit
Access	ro
Entry Category	Mandatory
PDO Mapping	No
Value Range	1 _h to FE _h
Default Value	No

Sub-Index	1 _h
Description	Interrupt High to Low 1 _h to 8 _h
Access	rw
Entry Category	Mandatory
PDO Mapping	Optional
Value Range	Unsigned8
Default Value	0 _h

Sub-Index	2 _h
Description	Interrupt High to Low 9 _h to 10 _h
Access	rw
Entry Category	Optional
PDO Mapping	Optional
Value Range	Unsigned8
Default Value	0 _h

to

Sub-Index	FE _h
Description	Interrupt High to Low 7F1 _h to 7F8 _h
Access	rw
Entry Category	Optional
PDO Mapping	Optional
Value Range	Unsigned8
Default Value	0 _h

8.1.8 Read Input Bit 1 to 128 .. Read Input Bit 897 to 1024 (6020_h .. 6027_h)

These objects shall read single input lines information. A maximum of 128 input lines is addressable at one index. The 6020_h object shall address the input lines 1 to 128, the 6021_h object shall address the input lines 129 to 256, etc.

Object Description

INDEX	6020 _h
Name	Read Input Bit 1 _h to 80 _h
Object Code	Array
Data Type	Boolean
Category	Optional

Entry Description

Sub-Index	0 _h
Description	Number of Inputs 1-Bit
Access	ro
Entry Category	Mandatory
PDO Mapping	No
Value Range	1 _h to 80 _h
Default Value	No

Sub-Index	1 _h
Description	Read Single Input 1 _h
Access	ro
Entry Category	Mandatory
PDO Mapping	Optional
Value Range	Boolean
Default Value	No

Sub-Index	2 _h
Description	Read Single Input 2 _h
Access	ro
Entry Category	Optional
PDO Mapping	Optional
Value Range	Boolean
Default Value	No

to

Sub-Index	80 _h
Description	Read Single Input 80 _h
Access	ro
Entry Category	Optional
PDO Mapping	Optional
Value Range	Boolean
Default Value	No

8.1.9 Polarity Input Bit 1 to 128 .. Polarity Input Bit 897 to 1024 (6030_h .. 6037_h)

These objects shall define the polarity of single input lines. A maximum of 128 input lines is addressable at one index. The 6030_h object shall address the input lines 1 to 128, the 6031_h object shall address the input lines 129 to 256, etc.

TRUE = input inverted FALSE = input not inverted

If these objects are not supported the device shall behave accordingly to the default value.

Object Description

INDEX	6030 _h
Name	Polarity Input Bit 1 _h to 80 _h
Object Code	Array
Data Type	Boolean
Category	Optional

Entry Description

Sub-Index	0 _h
Description	Number of Inputs 1-Bit
Access	ro
Entry Category	Mandatory
PDO Mapping	No
Value Range	1 _h to 80 _h
Default Value	No

Sub-Index	1 _h
Description	Polarity Input Bit 1 _h
Access	rw
Entry Category	Mandatory
PDO Mapping	Optional
Value Range	Boolean
Default Value	FALSE

Sub-Index	2 _h
Description	Polarity Input Bit 2 _h
Access	rw
Entry Category	Optional
PDO Mapping	Optional
Value Range	Boolean
Default Value	FALSE

to

Sub-Index	80 _h
Description	Polarity Input Bit 80 _h
Access	rw
Entry Category	Optional
PDO Mapping	Optional
Value Range	Boolean
Default Value	FALSE

8.1.10 Filter Constant Input Bit 1 to 128 .. Filter Constant Input Bit 897 to 1024 (6038_h .. 603F_h)

These objects shall enable and disable an additional configurable filter constant. If these objects are not supported, the device shall behave accordingly to the default value. The type of the filter constant and the configuration of the filter constant are manufacturer-specific. The 6038_h object shall address the input lines 1 to 128, the 6039_h object shall address the input lines 129 to 256, etc.

TRUE = enabled

FALSE = disabled

Object Description

INDEX	6038 _h
Name	Filter Constant Input Bit 1 _h to 80 _h
Object Code	Array
Data Type	Boolean
Category	Optional

Entry Description

Sub-Index	0 _h
Description	Number of Inputs 1-Bit
Access	ro
Entry Category	Mandatory
PDO Mapping	No
Value Range	1 _h to 80 _h
Default Value	No

Sub-Index	1 _h
Description	Filter Constant Input Bit 1 _h
Access	rw
Entry Category	Mandatory
PDO Mapping	Optional
Value Range	Boolean
Default Value	FALSE

Sub-Index	2 _h
Description	Filter Constant Input Bit 2 _h
Access	rw
Entry Category	Optional
PDO Mapping	Optional
Value Range	Boolean
Default Value	FALSE

to

Sub-Index	80 _h
Description	Filter Constant Input Bit 80 _h
Access	rw
Entry Category	Optional
PDO Mapping	Optional
Value Range	Boolean
Default Value	FALSE

8.1.11 Interrupt Mask Input Any Change Bit 1 to 128 .. Interrupt Mask Input Any Change Bit 897 to 1024 (6050_h .. 6057_h)

These objects shall set interrupt masks for single input lines. A maximum of 128 Bit inputs is addressable at one index. The 6050_h object shall address the input lines 1 to 128, the 6051_h object shall address the input lines 129 to 256, etc.

TRUE = interrupt enabled

FALSE = interrupt disabled

If the object is not supported, the device shall behave accordingly to the default value.

Object Description

INDEX	6050 _h
Name	Interrupt Mask Input Bit Any Change 1h to 80h
Object Code	Array
Data Type	Boolean
Category	Optional

Entry Description

Sub-Index	0 _h
Description	Number of Inputs 1-Bit
Access	ro
Entry Category	Mandatory
PDO Mapping	No
Value Range	1 _h to 80 _h
Default Value	No

Sub-Index	1 _h
Description	Interrupt Mask Any Change Input Bit 1 _h
Access	rw
Entry Category	Mandatory
PDO Mapping	Optional
Value Range	Boolean
Default Value	TRUE

Sub-Index	2 _h
Description	Interrupt Mask Any Change Input Bit 2 _h
Access	rw
Entry Category	Optional
PDO Mapping	Optional
Value Range	Boolean
Default Value	TRUE

to

Sub-Index	80 _h
Description	Interrupt Mask Any Change Input 80 _h
Access	rw
Entry Category	Optional
PDO Mapping	Optional
Value Range	Boolean
Default Value	TRUE

8.1.12 Interrupt Mask Input Low-to-High Bit 1 to 128 .. Interrupt Mask Input Low-to-High Bit 897 to 1024 (6060_h .. 6067_h)

These objects shall set interrupt masks for a single input line. A maximum of 128 Bit inputs is addressable at one index. The 6060_h object shall address the input lines 1 to 128, the 6061_h object shall address the input lines 129 to 256, etc. The values shall be in an "OR" connection to the values of 6050_h to 6057_h objects (Interrupt Mask Any Change). If inputs are inverted by 6030_h to 6037_h objects (Polarity Input), the positive logical edge shall correspond to negative physical edge.

TRUE = interrupt enabled FALSE = interrupt disabled

If the object is not supported, the device shall behave accordingly to the default value.

Object Description

INDEX	6060 _h
Name	Interrupt Mask Input Low to High Bit 1 _h to 80 _h
Object Code	Array
Data Type	Boolean
Category	Optional

Entry Description

Sub-Index	0 _h
Description	Number of Inputs 1-Bit
Access	rw
Entry Category	Mandatory
PDO Mapping	No
Value Range	1 _h to 80 _h
Default Value	No

Sub-Index	1 _h
Description	Interrupt Mask Low to High Input 1 _h
Access	rw
Entry Category	Mandatory
PDO Mapping	Optional
Value Range	Boolean
Default Value	FALSE

Sub-Index	2 _h
Description	Interrupt Mask Low to High Input 2 _h
Access	rw
Entry Category	Optional
PDO Mapping	Optional
Value Range	Boolean
Default Value	FALSE

to

Sub-Index	80 _h
Description	Interrupt Mask Low to High Input 80 _h
Access	rw
Entry Category	Optional
PDO Mapping	Optional
Value Range	Boolean
Default Value	FALSE

8.1.13 Interrupt Mask Input High-to-Low Bit 1 to 128 .. Interrupt Mask Input High-to-Low Bit 897 to 1024 (6070_h .. 6077_h)

These objects shall set interrupt masks for single input lines. A maximum of 128 Bit inputs is addressable at one index. The 6070_h object shall address the input lines 1 to 128, the 6071_h object shall address the input lines 129 to 256, etc. The values shall be in an "OR" connection to the values of 6050_h to 6057_h objects (Interrupt Mask Any Change). If inputs are inverted by 6030_h to 6037_h objects (Polarity Input), the negative logical edge shall correspond to positive physical edge.

TRUE = interrupt enabled

FALSE = interrupt disabled

If the object is not supported, the device shall behave accordingly to the default value.

Object Description

INDEX	6070 _h
Name	Interrupt Mask Input High to Low Bit 1 _h to 80 _h
Object Code	Array
Data Type	Boolean
Category	Optional

Entry Description

Sub-Index	0 _h
Description	Number of Inputs 1-Bit
Access	rw
Entry Category	Mandatory
PDO Mapping	No
Value Range	1 _h to 80 _h
Default Value	No

Sub-Index	1 _h
Description	Interrupt Mask High to Low Input 1 _h
Access	rw
Entry Category	Mandatory
PDO Mapping	Optional
Value Range	Boolean
Default Value	FALSE

Sub-Index	2 _h
Description	Interrupt Mask High to Low Input 2 _h
Access	rw
Entry Category	Optional
PDO Mapping	Optional
Value Range	Boolean
Default Value	FALSE

to

Sub-Index	80 _h
Description	Interrupt Mask High to Low Input 80 _h
Access	rw
Entry Category	Optional
PDO Mapping	Optional
Value Range	Boolean
Default Value	FALSE
Default Value	FALSE

8.1.14 Read Input 16-bit (6100_h)

The object shall read a group of 16 input lines as a 16-bit information. A maximum of 254 x 16-Bit words is addressable (4064 inputs).

1 = input inverted

0 = input not inverted

Object Description

INDEX	6100 _h
Name	Read Input 16-bit
Object Code	Array
Data Type	Unsigned16
Category	Optional

Entry Description

Sub-Index	0 _h
Description	Number of Inputs 16-Bit
Access	ro
Entry Category	Mandatory
PDO Mapping	No
Value Range	1 _h to FE _h
Default Value	No

Sub-Index	1 _h
Description	Read Input 1 _h to 10 _h
Access	ro
Entry Category	Mandatory
PDO Mapping	Optional
Value Range	Unsigned16
Default Value	No

Sub-Index	2 _h
Description	Read Input 11 _h to 20 _h
Access	ro
Entry Category	Optional
PDO Mapping	Optional
Value Range	Unsigned16
Default Value	No

to

Sub-Index	FE _h
Description	Read Input FD0 _h to FE0 _h
Access	ro
Entry Category	Optional
PDO Mapping	Optional
Value Range	Unsigned16
Default Value	No

8.1.15 Polarity Input 16-bit (6102_h)

This object shall define the polarity for a group of 16 input lines. Inputs can be inverted individually.

1 = input inverted 0 = input not inverted

If the object is not supported the device shall behave accordingly to the default value.

Object Description

INDEX	6102 _h
Name	Polarity Input 16-bit
Object Code	Array
Data Type	Unsigned16
Category	Optional

Entry Description

Sub-Index	0 _h
Description	Number of Inputs 16-Bit
Access	ro
Entry Category	Mandatory
PDO Mapping	No
Value Range	1 _h to FE _h
Default Value	No

Sub-Index	1 _h
Description	Polarity Input 1 _h to 10 _h
Access	rw
Entry Category	Mandatory
PDO Mapping	Optional
Value Range	Unsigned16
Default Value	0 _h

Sub-Index	2 _h
Description	Polarity Input 11 _h to 20 _h
Access	rw
Entry Category	Optional
PDO Mapping	Optional
Value Range	Unsigned16
Default Value	0 _h

to

Sub-Index	FE _h
Description	Polarity Input FD1 _h to FF0 _h
Access	rw
Entry Category	Optional
PDO Mapping	Optional
Value Range	Unsigned16
Default Value	0 _h

8.1.16 Filter Constant Input 16-bit (6103_h)

This object shall enable and disable an additional configurable filter constant. If the object is not supported, the device shall behave accordingly to the default value. The type of the filter constant and the configuration of the filter constant are manufacturer-specific.

1 = enabled 0 = disabled

Object Description

INDEX	6103 _h
Name	Filter Constant Input 16-bit
Object Code	Array
Data Type	Unsigned16
Category	Optional

Entry Description

Sub-Index	0 _h
Description	Number of Inputs 16-Bit
Access	ro
Entry Category	Mandatory
PDO Mapping	No
Value Range	1 _h to FE _h
Default Value	No

Sub-Index	1 _h
Description	Filter Constant Input 1 _h to 10 _h
Access	rw
Entry Category	Mandatory
PDO Mapping	Optional
Value Range	Unsigned16
Default Value	0 _h

Sub-Index	2 _h
Description	Filter Constant Input 11 _h to 20 _h
Access	rw
Entry Category	Optional
PDO Mapping	Optional
Value Range	Unsigned16
Default Value	0 _h

to

Sub-Index	FE _h
Description	Filter Constant Input FD1 _h to FE0 _h
Access	rw
Entry Category	Optional
PDO Mapping	Optional
Value Range	Unsigned16
Default Value	0 _h

8.1.17 Interrupt Mask Input Any Change 16-bit (6106_h)

This object determines, which input port lines shall activate an interrupt. Done for groups of 16 lines and for any change of a digital input line.

1 = interrupt enabled 0 = interrupt disabled

If the object is not supported, the device shall behave accordingly to the default value.

Object Description

INDEX	6106 _h
Name	Interrupt Mask Input Any Change 16-bit
Object Code	Array
Data Type	Unsigned16
Category	Optional

Entry Description

Sub-Index	0 _h
Description	Number of Inputs 16-Bit
Access	ro
Entry Category	Mandatory
PDO Mapping	No
Value Range	1 _h to FE _h
Default Value	No

Sub-Index	1 _h
Description	Interrupt Any Change Inputs 1 _h to 10 _h
Access	rw
Entry Category	Mandatory
PDO Mapping	Optional
Value Range	Unsigned16
Default Value	FFFF _h

Sub-Index	2 _h
Description	Interrupt Any Change Inputs 11 _h to 20 _h
Access	rw
Entry Category	Optional
PDO Mapping	Optional
Value Range	Unsigned16
Default Value	FFFF _h

to

Sub-Index	FE _h
Description	Interrupt Any Change Inputs FD1 _h to FE0 _h
Access	rw
Entry Category	Optional
PDO Mapping	Optional
Value Range	Unsigned16
Default Value	FFFF _h

8.1.18 Interrupt Mask Input Low-to-High 16-bit (6107_h)

This object determines, which input port lines shall activate an interrupt. Done for groups of 16 lines and for a change from low-to-high of a digital input line. The values shall be in an "OR" connection to the values of 6106_h object (Interrupt Mask Any Change 16-Bit). If inputs are inverted by 6102_h object (Polarity Input 16-Bit), the positive logical edge shall correspond to negative physical edge.

1 = interrupt enabled 0 = interrupt disabled

If the object is not supported, the device shall behave accordingly to the default value.

Object Description

INDEX	6107 _h
Name	Interrupt Mask Input Low to High 16-bit
Object Code	Array
Data Type	Unsigned16
Category	Optional

Entry Description

Sub-Index	0 _h
Description	Number of Inputs 16-Bit
Access	ro
Entry Category	Mandatory
PDO Mapping	No
Value Range	1 _h to FE _h
Default Value	No

Sub-Index	1 _h
Description	Interrupt Low to High Inputs 1 _h to 10 _h
Access	rw
Entry Category	Mandatory
PDO Mapping	Optional
Value Range	Unsigned16
Default Value	0 _h

Sub-Index	2 _h
Description	Interrupt Low to High Inputs 11 _h to 20 _h
Access	rw
Entry Category	Optional
PDO Mapping	Optional
Value Range	Unsigned16
Default Value	0 _h

to

Sub-Index	FE _h
Description	Interrupt Low to High Inputs FD1 _h to FE0 _h
Access	rw
Entry Category	Optional
PDO Mapping	Optional
Value Range	Unsigned16
Default Value	0 _h

8.1.19 Interrupt Mask Input High-to-Low 16-bit (6108_h)

This object determines, which input port lines shall activate an interrupt. Done for groups of 16 lines and for a change from high-to-low of a digital input line. The values shall be in an "OR" connection to the values of 6106_h object (Interrupt Mask Any Change 16-Bit). If inputs are inverted by 6102_h object (Polarity Input 16-Bit), the negative logical edge shall correspond to positive physical edge.

1 = interrupt enabled 0 = interrupt disabled

If the object is not supported, the device shall behave accordingly to the default value.

Object Description

INDEX	6108 _h
Name	Interrupt Mask Input High to Low 16-bit
Object Code	Array
Data Type	Unsigned16
Category	Optional

Entry Description

Sub-Index	0 _h
Description	Number of Inputs 16-Bit
Access	ro
Entry Category	Mandatory
PDO Mapping	No
Value Range	1 _h to FE _h
Default Value	No

Sub-Index	1 _h
Description	Interrupt High to Low Inputs 1 _h to 10 _h
Access	rw
Entry Category	Mandatory
PDO Mapping	Optional
Value Range	Unsigned16
Default Value	0 _h

Sub-Index	2 _h
Description	Interrupt High to Low Inputs 11 _h to 20 _h
Access	rw
Entry Category	Optional
PDO Mapping	Optional
Value Range	Unsigned16
Default Value	0 _h

to

Sub-Index	FE _h
Description	Interrupt High to Low Inputs FD1 _h to FE0 _h
Access	rw
Entry Category	Optional
PDO Mapping	Optional
Value Range	Unsigned16
Default Value	0 _h

8.1.20 Read Input 32-bit (6120_h)

This object shall read a group of 32 input lines as 32-bit information. A maximum of 254 x 32-Bit words is addressable (8128 inputs).

Object Description

INDEX	6120 _h
Name	Read Input 4 Byte
Object Code	Array
Data Type	Unsigned32
Category	Optional

Entry Description

Sub-Index	0 _h
Description	Number of Inputs 32-Bit
Access	ro
Entry Category	Mandatory
PDO Mapping	No
Value Range	1 _h to FE _h
Default Value	No

Sub-Index	1 _h
Description	Read Inputs 1 _h to 20 _h
Access	ro
Entry Category	Mandatory
PDO Mapping	Optional
Value Range	Unsigned32
Default Value	No

Sub-Index	2 _h
Description	Read Inputs 21 _h to 40 _h
Access	ro
Entry Category	Optional
PDO Mapping	Optional
Value Range	Unsigned32
Default Value	No

to

Sub-Index	FE _h
Description	Read Inputs 1FA0 _h to 1FC0 _h
Access	ro
Entry Category	Optional
PDO Mapping	Optional
Value Range	Unsigned32
Default Value	No

8.1.21 Polarity Input 32-bit (6122_h)

This object shall define the polarity for a group of 32 input lines. Inputs can be inverted individually.

1 = input inverted 0 = input not inverted

If the object is not supported the device shall behave accordingly to the default value.

Object Description

INDEX	6122 _h
Name	Polarity Input 32-bit
Object Code	Array
Data Type	Unsigned32
Category	Optional

Entry Description

Sub-Index	0 _h
Description	Number of Inputs 32-Bit
Access	ro
PDO Mapping	No
Value Range	1 _h to FE _h
Default Value	0 _h

Sub-Index	1 _h
Description	Polarity Inputs 1 _h to 20 _h
Access	rw
Entry Category	Mandatory
PDO Mapping	No
Value Range	Unsigned32
Default Value	0 _h

Sub-Index	2 _h
Description	Polarity Inputs 21 _h to 40 _h
Access	rw
Entry Category	Optional
PDO Mapping	No
Value Range	Unsigned32
Default Value	0 _h

to

Sub-Index	FE _h
Description	Polarity Inputs 1FA0 _h to 1FC0 _h
Access	rw
Entry Category	Optional
PDO Mapping	Optional
Value Range	Unsigned32
Default Value	0 _h

8.1.22 Filter Constant Input 32-bit (6123_h)

This object shall enable and disable an additional configurable filter constant. If the object is not supported, the device shall behave accordingly to the default value. The type of the filter constant and the configuration of the filter constant are manufacturer-specific.

1 = enabled 0 = disabled

Object Description

INDEX	6123 _h
Name	Filter Constant Input 32-bit
Object Code	Array
Data Type	Unsigned32
Category	Optional

Entry Description

Sub-Index	0 _h
Description	Number of Inputs 32-Bit
Access	ro
Entry Category	Mandatory
PDO Mapping	No
Value Range	1 _h to FE _h
Default Value	No

Sub-Index	1 _h
Description	Filter Constant Inputs 1 _h to 20
Access	rw
Entry Category	Mandatory
PDO Mapping	Optional
Value Range	Unsigned32
Default Value	0 _h

Sub-Index	2 _h
Description	Filter Constant Inputs 21 _h to 40 _h
Access	rw
Entry Category	Optional
PDO Mapping	Optional
Value Range	Unsigned32
Default Value	0 _h

to

Sub-Index	FE _h
Description	Filter Constant Inputs 1FA1 _h to 1FC0 _h
Access	rw
Entry Category	Optional
PDO Mapping	Optional
Value Range	Unsigned32
Default Value	0 _h

8.1.23 Interrupt Mask Input Any Change 32-bit (6126_h)

This object determines which input port lines shall activate an interrupt. Done for groups of 32 lines and for any change of a digital input line.

1 = interrupt enabled 0 = interrupt disabled

If the object is not supported, the device shall behave accordingly to the default value.

Object Description

INDEX	6126 _h
Name	Interrupt Mask Input Any Change 32-bit
Object Code	Array
Data Type	Unsigned32
Category	Optional

Entry Description

Sub-Index	0 _h
Description	Number of Inputs 32-Bit
Access	ro
Entry Category	Mandatory
PDO Mapping	No
Value Range	1 _h to FE _h
Default Value	No

Sub-Index	1 _h
Description	Interrupt Any Change Input 1 _h to 20 _h
Access	rw
Entry Category	Mandatory
PDO Mapping	Optional
Value Range	Unsigned32
Default Value	FFFF FFFF _h

Sub-Index	2 _h
Description	Interrupt Any Change Input 21 _h to 40 _h
Access	rw
Entry Category	Optional
PDO Mapping	Optional
Value Range	Unsigned32
Default Value	FFFF FFFF _h

to

Sub-Index	FE _h
Description	Interrupt Any Change Input 1FA1 _h to 1FC0 _h
Access	rw
Entry Category	Optional
PDO Mapping	Optional
Value Range	Unsigned32
Default Value	FFFF FFFF _h

8.1.24 Interrupt Mask Input Low-to-High 32-bit (6127_h)

This object determines, which input port lines shall activate an interrupt. Done for groups of 32 lines and for a change from low-to-high of a digital input line. The values shall be in an "OR" connection to the values of 6126_h object (Interrupt Mask Any Change 32-Bit). If inputs are inverted by 6122_h object (Polarity Input 32-Bit), the positive logical edge shall correspond to negative physical edge.

1 = interrupt enabled 0 = interrupt disabled

If the object is not supported, the device shall behave accordingly to the default value.

Object Description

INDEX	6127 _h
Name	Interrupt Mask Input Low to High 32-bit
Object Code	Array
Data Type	Unsigned32
Category	Optional

Entry Description

Sub-Index	0 _h
Description	Number of Inputs 32-Bit
Access	ro
Entry Category	Mandatory
PDO Mapping	No
Value Range	1 _h to FE _h
Default Value	No

Sub-Index	1 _h
Description	Interrupt Low to High Input 1 _h to 20 _h
Access	rw
Entry Category	Mandatory
PDO Mapping	Optional
Value Range	Unsigned32
Default Value	0 _h

Sub-Index	2 _h
Description	Interrupt Low to High Input 21 _h to 40 _h
Access	rw
Entry Category	Optional
PDO Mapping	Optional
Value Range	Unsigned32
Default Value	0 _h

to

Sub-Index	FE _h
Description	Interrupt Low to High Input 1FA1 _h to 1FC0 _h
Access	rw
Entry Category	Optional
PDO Mapping	Optional
Value Range	Unsigned32
Default Value	0 _h

8.1.25 Interrupt Mask Input High-to-Low 32-bit (6128_h)

This object determines, which input port lines shall activate an interrupt. Done for groups of 32 lines and for a change from high-to-low of a digital input line. The values shall be in an "OR" connection to the values of 6126_h object (Interrupt Mask Any Change 32-Bit). If inputs are inverted by 6122_h object (Polarity Input 32-Bit), the negative logical edge shall correspond to positive physical edge.

1 = interrupt enabled 0 = interrupt disabled

If the object is not supported, the device shall behave accordingly to the default value.

Object Description

INDEX	6128 _h
Name	Interrupt Mask Input High to Low 32-bit
Object Code	Array
Data Type	Unsigned32
Category	Optional

Entry Description

Sub-Index	0 _h
Description	Number of Inputs 32-Bit
Access	ro
Entry Category	Mandatory
PDO Mapping	No
Value Range	1 _h to FE _h
Default Value	No

Sub-Index	1 _h
Description	Interrupt High to Low Input 1 _h to 20 _h
Access	rw
Entry Category	Mandatory
PDO Mapping	Optional
Value Range	Unsigned32
Default Value	0 _h

Sub-Index	2 _h
Description	Interrupt High to Low Input 21 _h to 40 _h
Access	rw
Entry Category	Optional
PDO Mapping	Optional
Value Range	Unsigned32
Default Value	0 _h

to

Sub-Index	FE _h
Description	Interrupt High to Low Input 1FA1 _h to 1FC0 _h
Access	rw
Entry Category	Optional
PDO Mapping	Optional
Value Range	Unsigned32
Default Value	0 _h

8.2 Digital output module

8.2.1 Write Output 8-Bit (6200_h)

This object shall set a group of 8 output lines as a Byte of information. A maximum of 254 x 8 Bit output blocks is addressable.

Object Description

INDEX	6200 _h
Name	Write Output 8-Bit
Object Code	Array
Data Type	Unsigned8
Category	Conditional: Device with digital outputs

Entry Description

Sub-Index	0 _h
Description	Number of Outputs 8-Bit
Access	ro
Entry Category	Mandatory
PDO Mapping	No
Value Range	1 _h to FE _h
Default Value	No

Sub-Index	1 _h
Description	Write Output 1 _h to 8 _h
Access	rw
Entry Category	Mandatory
PDO Mapping	Default
Value Range	Unsigned8
Default Value	0 _h

Sub-Index	2 _h
Description	Write Output 9 _h to 10 _h
Access	rw
Entry Category	Optional
PDO Mapping	Default
Value Range	Unsigned8
Default Value	0 _h

to

Sub-Index	8 _h
Description	Write Output 39 _h to 40 _h
Access	rw
Entry Category	Optional
PDO Mapping	Default
Value Range	Unsigned8
Default Value	0 _h

Sub-Index	9 _h
Description	Write Output 41 _h to 48 _h
Access	rw
Entry Category	Optional
PDO Mapping	Optional
Value Range	Unsigned8
Default Value	0 _h

to

Sub-Index	FE _h
Description	Write Output 7E9 _h to 7F0 _h
Access	rw
Entry Category	Optional
PDO Mapping	Optional
Value Range	Unsigned8
Default Value	0 _h

8.2.3 Change Polarity Output 8-Bit (6202_h)

This object shall define the polarity of a group of 8 output lines. Output polarity can be inverted individually.

1 = output inverted 0 = output not inverted

If the object is not supported, the device shall behave accordingly to the default value.

Object Description

INDEX	6202 _h
Name	Change Polarity Output 8-Bit
Object Code	Array
Data Type	Unsigned8
Category	Optional

Entry Description

Sub-Index	0 _h
Description	Number of Outputs 8-Bit
Access	ro
Entry Category	Mandatory
PDO Mapping	No
Value Range	1 _h to FE _h
Default Value	No

Sub-Index	1 _h
Description	Change Polarity Output 1 _h to 8 _h
Access	rw
Entry Category	Mandatory
PDO Mapping	Optional
Value Range	Unsigned8
Default Value	0 _h

Sub-Index	2 _h
Description	Change Polarity Output 9 _h to 10 _h
Access	rw
Entry Category	Optional
PDO Mapping	Optional
Value Range	Unsigned8
Default Value	0 _h

to

Sub-Index	FE _h
Description	Change Polarity Output 7E9 _h to 7F0 _h
Access	rw
Entry Category	Optional
PDO Mapping	Optional
Value Range	Unsigned8
Default Value	0 _h

8.2.4 Error Mode Output 8-Bit (6206_h)

This object indicates, whether an output is set to a pre-defined error value (see 6207_h object) in case of an internal device failure or a 'Stop Remote Node' indication.

1 = output value shall take the pre-defined condition specified in 6207_h object

0 = output value shall be kept if an error occurs

If the object is not supported, the device shall behave accordingly to the default value.

Object Description

INDEX	6206 _h
Name	Error Mode Output 8-Bit
Object Code	Array
Data Type	Unsigned8
Category	Optional

Entry Description

Sub-Index	0 _h
Description	Number of Outputs 8-Bit
Access	ro
Entry Category	Mandatory
PDO Mapping	No
Value Range	1 _h to FE _h
Default Value	No

Sub-Index	1 _h
Description	Error Mode Output 1 _h to 8 _h
Access	rw
Entry Category	Mandatory
PDO Mapping	Optional
Value Range	Unsigned8
Default Value	FF _h

Sub-Index	2 _h
Description	Error Mode Output 9 _h to 10 _h
Access	rw
Entry Category	Optional
PDO Mapping	Optional
Value Range	Unsigned8
Default Value	FF _h

to

Sub-Index	FE _h
Description	Error Mode Output 7E9 _h to 7F0 _h
Access	rw
Entry Category	Optional
PDO Mapping	Optional
Value Range	Unsigned8
Default Value	FF _h

8.2.5 Error Value Output 8-Bit (6207_h)

On condition that the corresponding Error Mode is active, device failures (see chapter 5.2) shall set the outputs to the value configured by this object.

0 = Output shall be set to '0' in case of fault, if 6206_h object is enabled

1 = Output shall be set to '1' in case of fault, if 6206_h object is enabled

If the object is not supported, the device shall behave accordingly to the default value.

Object Description

INDEX	6207 _h
Name	Error Value Output 8-Bit
Object Code	Array
Data Type	Unsigned8
Category	Optional

Entry Description

Sub-Index	0 _h
Description	Number of Outputs 8-Bit
Access	ro
Entry Category	Mandatory
PDO Mapping	No
Value Range	1 _h to FE _h
Default Value	No

Sub-Index	1 _h
Description	Error Value Output 1 _h to 8 _h
Access	rw
Entry Category	Mandatory
PDO Mapping	Optional
Value Range	Unsigned8
Default Value	0 _h

Sub-Index	2 _h
Description	Error Value Output 9 _h to 10 _h
Access	rw
Entry Category	Optional
PDO Mapping	Optional
Value Range	Unsigned8
Default Value	0 _h

to

Sub-Index	FE _h
Description	Error Value Output 7E9 _h to 7F0 _h
Access	rw
Entry Category	Optional
PDO Mapping	Optional
Value Range	Unsigned8
Default Value	0 _h

8.2.6 Filter Mask Output 8-Bit (6208_h)

This object defines an additional configurable output filter mask for a group of 8 outputs.

1 = output shall be set to the received output value

0 = don't care, the received output value is neglected for the appropriated output channel, the old output value shall be kept.

If the object is not supported, the device shall behave accordingly to the default value.

Object Description

INDEX	6208 _h
Name	Filter Mask Output 8-Bit
Object Code	Array
Data Type	Unsigned8
Category	Optional

Entry Description

Sub-Index	0 _h
Description	Number of Outputs 8-Bit
Access	ro
Entry Category	Mandatory
PDO Mapping	No
Value Range	1 _h to FE _h
Default Value	No

Sub-Index	1 _h
Description	Filter Mask Output 1 _h to 8 _h
Access	rw
Entry Category	Mandatory
PDO Mapping	Optional
Value Range	Unsigned8
Default Value	FF _h

Sub-Index	2 _h
Description	Filter Mask Output 9 _h to 10 _h
Access	rw
Entry Category	Optional
PDO Mapping	Optional
Value Range	Unsigned8
Default Value	FF _h

to

Sub-Index	FE _h
Description	Filter Mask Output 7E9 _h to 7F0 _h
Access	rw
Entry Category	Optional
PDO Mapping	Optional
Value Range	Unsigned8
Default Value	FF _h

8.2.7 Write Output Bit 1 to 128 .. Write Output Bit 897 to 1024 (6220_h .. 6227_h)

These objects shall set single output lines information. A maximum of 128 outputs is addressable at one index. The 6220_h object shall address output lines 1 to 128, the 6221_h object shall address output lines 129 to 256, etc.

Object Description

INDEX	6220 _h
Name	Write Output Bit 1 to 128
Object Code	Array
Data Type	Boolean
Category	Optional

Entry Description

Sub-Index	0 _h
Description	Number of Outputs 1-Bit
Access	ro
Entry Category	Mandatory
PDO Mapping	No
Value Range	1 _h to 80 _h
Default Value	No

Sub-Index	1 _h
Description	Write Output 1
Access	rw
Entry Category	Mandatory
PDO Mapping	Optional
Value Range	Boolean
Default Value	FALSE

Sub-Index	2 _h
Description	Write Output 2 _h
Access	rw
Entry Category	Optional
PDO Mapping	Optional
Value Range	Boolean
Default Value	FALSE

to

Sub-Index	80 _h
Description	Write Output 80 _h
Access	rw
Entry Category	Optional
PDO Mapping	Optional
Value Range	Boolean
Default Value	FALSE

8.2.8 Change Polarity Output Bit 1 to 128 .. Change Polarity Output Bit 897 to 1024 (6240_h .. 6247_h)

These objects shall set the polarity of single output lines. A maximum of 128 outputs is addressable at one index. The 6240_h object shall address output lines 1 to 128, the 6241_h object shall address output lines 129 to 256, etc.

TRUE = output inverted FALSE = output not inverted

If these objects are not supported the device shall behave accordingly to the default value.

Object Description

INDEX	6240 _h
Name	Change Polarity Output Bit 1 to 128
Object Code	Array
Data Type	Boolean
Category	Optional

Entry Description

Sub-Index	0 _h
Description	Number of Outputs 1-Bit
Access	ro
Entry Category	Mandatory
PDO Mapping	No
Value Range	1 _h to 80 _h
Default Value	No

Sub-Index	1 _h
Description	Change Polarity Output 1 _h
Access	rw
Entry Category	Mandatory
PDO Mapping	Optional
Value Range	Boolean
Default Value	FALSE

Sub-Index	2 _h
Description	Change Polarity Output 2 _h
Access	rw
Entry Category	Optional
PDO Mapping	Optional
Value Range	Boolean
Default Value	FALSE

to

Sub-Index	80 _h
Description	Change Polarity Output 80 _h
Access	rw
Entry Category	Optional
PDO Mapping	Optional
Value Range	Boolean
Default Value	FALSE

8.2.9 Error Mode Output Bit 1 to 128 .. Error Mode Output Bit 897 to 1024 (6250_h .. 6257_h)

These objects indicate, whether an output is set to a pre-defined error value (see 6260_h .. 6267_h objects) in case of an internal device failure a 'Stop Remote Node' indication. A maximum of 128 outputs is addressable at one index. The 6250_h object shall address output lines 1 to 128, the 6251_h object shall address output lines 129 to 256, etc.

TRUE = output value shall take the pre-defined condition as specified in 6260_h .. 6267_h objects

FALSE = output value shall be kept if an error occurs

If the object is not supported, the device shall behave accordingly to the default value.

Object Description

INDEX	6250
Name	Error Mode Output Lines 1 to 128
Object Code	Array
Data Type	Boolean
Category	Optional

Entry Description

Sub-Index	0 _h
Description	Number of Outputs 1-Bit
Access	ro
Entry Category	Mandatory
PDO Mapping	No
Value Range	1 _h to 80 _h
Default Value	No

Sub-Index	1 _h
Description	Error Mode Output 1 _h
Access	rw
Entry Category	Mandatory
PDO Mapping	Optional
Value Range	Boolean
Default Value	TRUE

Sub-Index	2 _h
Description	Error Mode Output 2 _h
Access	rw
Entry Category	Optional
PDO Mapping	Optional
Value Range	Boolean
Default Value	TRUE

to

Sub-Index	80 _h
Description	Error Mode Output 80 _h
Access	rw
Entry Category	Optional
PDO Mapping	Optional
Value Range	Boolean
Default Value	TRUE

8.2.10 Error Value Output Bit 1 to 128 .. Error Value Output Bit 897 to 1024 (6260_h .. 6267_h)

On condition that the corresponding Error Mode is active, device failures (see chapter 5.2) shall set the outputs to the value configured by this object. A maximum of 128 outputs is addressable at one index. The 6260_h object shall address output lines 1 to 128, the 6261_h object shall address output lines 129 to 256, etc.

FALSE = Output shall be set to '0' in case of fault, if the corresponding object (6250_h .. 6257_h) is enabled

TRUE = Output shall be set to '1' in case of fault, if the corresponding object (6250_h .. 6257_h) is enabled

If the object is not supported, the device shall behave accordingly to the default value.

Object Description

INDEX	6260 _h
Name	Error Value Output Bit 1 to 128
Object Code	Array
Data Type	Boolean
Category	Optional

Entry Description

Sub-Index	0 _h
Description	Number of Outputs 1-Bit
Access	ro
Entry Category	Mandatory
PDO Mapping	No
Value Range	1 _h to 80 _h
Default Value	No
Default Value	No

Sub-Index	1 _h
Description	Error Value Output 1 _h
Access	rw
Entry Category	Mandatory
PDO Mapping	Optional
Value Range	Boolean
Default Value	FALSE

Sub-Index	2 _h
Description	Error Value Output 2 _h
Access	rw
Entry Category	Optional
PDO Mapping	Optional
Value Range	Boolean
Default Value	FALSE

to

Sub-Index	80 _h
Description	Error Value Output 80 _h
Access	rw
Entry Category	Optional
PDO Mapping	Optional
Value Range	Boolean
Default Value	FALSE

8.2.11 Filter Mask Output Bit 1 to 128 .. Filter Mask Bit 897 to 1024 (6270_h ..6277_h)

This object defines an additional configurable output filter mask for a single output.

TRUE = output shall set to the received output value

FALSE = don't care the received output value is neglected for the appropriated output channel, the old output value shall be kept

A maximum of 128 outputs is addressable at one index. The 6270_h object shall address output lines 1 to 128, the 6271_h object shall address output lines 129 to 256, etc.

If the object is not supported, the device shall behave accordingly to the default value.

Object Description

INDEX	6270 _h
Name	Filter Constant Output Bit 1 to 128
Object Code	Array
Data Type	Boolean
Category	Optional

Entry Description

Sub-Index	0 _h
Description	Number of Outputs 1-Bit
Access	ro
Entry Category	Mandatory
PDO Mapping	No
Value Range	1 _h to 80 _h
Default Value	No

Sub-Index	1 _h
Description	Filter Constant Output 1 _h
Access	rw
Entry Category	Mandatory
PDO Mapping	Optional
Value Range	Boolean
Default Value	TRUE

Sub-Index	2 _h
Description	Filter Constant Output 2 _h
Data Type	Boolean
Access	rw
Entry Category	Optional
PDO Mapping	Optional
Value Range	Boolean
Default Value	TRUE

to

Sub-Index	80 _h
Description	Filter Constant Output 80 _h
Data Type	Boolean
Access	rw
Entry Category	Optional
PDO Mapping	Optional
Value Range	Boolean
Default Value	TRUE

8.2.12 Write Output 16-bit (6300_h)

This object shall set a group of 16 output lines as 2-Byte information. A maximum of 255 x 16-Bit words is addressable (4080 outputs).

Object Description

INDEX	6300 _h
Name	Write Output 16-Bit
Object Code	Array
Data Type	Unsigned16
Category	Optional

Entry Description

Sub-Index	0 _h
Description	Number of Outputs 16-Bit
Access	ro
Entry Category	Mandatory
PDO Mapping	No
Value Range	1 _h to FE _h
Default Value	No

Sub-Index	1 _h
Description	Write Output 1 _h to 10 _h
Access	rw
Entry Category	Mandatory
PDO Mapping	Optional
Value Range	Unsigned16
Default Value	0 _h

Sub-Index	2 _h
Description	Write Output 11 _h to 20 _h
Access	rw
Entry Category	Optional
PDO Mapping	Optional
Value Range	Unsigned16
Default Value	0 _h

to

Sub-Index	FE _h
Description	Write Output FE0 _h to FF0 _h
Access	rw
Entry Category	Optional
PDO Mapping	Optional
Value Range	Unsigned16
Default Value	0 _h

8.2.13 Change Polarity Output 16-Bit (6302_h)

This object shall define the polarity for a group of 16 output lines. Output polarity can be inverted individually.

1 = enabled 0 = disabled

If the object is not supported the device shall behave accordingly to the default value.

Object Description

INDEX	6302 _h
Name	Change Polarity Output 16-Bit
Object Code	Array
Data Type	Unsigned16
Category	Optional

Entry Description

Sub-Index	0 _h
Description	Number of Outputs 16-Bit
Access	ro
Entry Category	Mandatory
PDO Mapping	No
Value Range	1 _h to FE _h
Default Value	No

Sub-Index	1 _h
Description	Polarity Output 1 _h to 10 _h
Data Type	Unsigned16
Access	rw
Entry Category	Mandatory
PDO Mapping	No
Value Range	Unsigned16
Default Value	0 _h

Sub-Index	2 _h
Description	Polarity Output 11 _h to 20 _h
Access	rw
Entry Category	Optional
PDO Mapping	Optional
Value Range	Unsigned16
Default Value	0 _h

to

Sub-Index	FE _h
Description	Polarity Output FE0 _h to FF0 _h
Access	rw
Entry Category	Optional
PDO Mapping	Optional
Value Range	Unsigned16
Default Value	0 _h

8.2.14 Error Mode Output 16-Bit (6306_h)

These objects indicate, whether an output is set to a pre-defined error value (see 6307_h object) in case of an internal device failure a 'Stop Remote Node' indication.

1 = output value shall take the pre-defined condition as specified in 6307_h object

0 = output value shall be kept if an error occurs

If the object is not supported, the device shall behave accordingly to the default value.

Object Description

INDEX	6306 _h
Name	Error Mode Output 16-Bit
Object Code	Array
Data Type	Unsigned16
Category	Optional

Entry Description

Sub-Index	0 _h
Description	Number of Outputs 16-Bit
Access	ro
Entry Category	Mandatory
PDO Mapping	No
Value Range	1 _h to FE _h
Default Value	No

Sub-Index	1 _h
Description	Error Mode Output 1 _h to 10 _h
Access	rw
Entry Category	Mandatory
PDO Mapping	Optional
Value Range	Unsigned16
Default Value	FFFF _h

Sub-Index	2 _h
Description	Error Mode Output 11 _h to 20 _h
Access	rw
Entry Category	Optional
PDO Mapping	Optional
Value Range	Unsigned16
Default Value	FFFF _h

to

Sub-Index	FE _h
Description	Error Mode Output FE0 _h to FF0 _h
Access	rw
Entry Category	Optional
PDO Mapping	Optional
Value Range	Unsigned16
Default Value	FFFF _h

8.2.15 Error Value Output 16-Bit (6307_h)

On condition that the corresponding Error Mode is active, device failures (see chapter 5.2) shall set the outputs to the value configured by this object.

0 = Output shall be set to '0' in case of fault, if 6306_h object is enabled

1 = Output shall be set to '1' in case of fault, if 6306_h object is enabled

If the object is not supported, the device shall behave accordingly to the default value.

Object Description

INDEX	6307 _h
Name	Error Value Output 16-Bit
Object Code	Array
Data Type	Unsigned16
Category	Optional

Entry Description

Sub-Index	0 _h
Description	Number of Outputs 16-Bit
Access	ro
Entry Category	Mandatory
PDO Mapping	No
Value Range	1 _h to FE _h
Default Value	No

Sub-Index	1 _h
Description	Error Value Output 1 _h to 10 _h
Access	rw
Entry Category	Mandatory
PDO Mapping	Optional
Value Range	Unsigned16
Default Value	0 _h

Sub-Index	2 _h
Description	Error Value Output 11 _h to 20 _h
Access	rw
Entry Category	Optional
PDO Mapping	Optional
Value Range	Unsigned16
Default Value	0 _h

to

Sub-Index	FE _h
Description	Error Value Output FE0 _h to FF0 _h
Access	rw
Entry Category	Optional
PDO Mapping	Optional
Value Range	Unsigned16
Default Value	0 _h

8.2.16 Filter Mask Output 16-Bit (6308_h)

This object defines an additional configurable output filter mask for a group of 16 outputs.

1 = output is shall set to the received output value

0 = don't care, the received output value is neglected for the appropriated output channel, the old output value shall be kept.

If the object is not supported, the device shall behave accordingly to the default value.

Object Description

INDEX	6308 _h
Name	Filter Mask Output 16-Bit
Object Code	Array
Data Type	Unsigned16
Category	Optional

Entry Description

Sub-Index	0 _h
Description	Number of Outputs 16-Bit
Access	ro
Entry Category	Mandatory
PDO Mapping	No
Value Range	1 _h to FE _h
Default Value	No

Sub-Index	1 _h
Description	Filter Mask Output 1 _h to 10 _h
Access	rw
Entry Category	Optional
PDO Mapping	Optional
Value Range	Unsigned16
Default Value	FFFF _h

Sub-Index	2 _h
Description	Filter Mask Output 11 _h to 20 _h
Access	rw
Entry Category	Optional
PDO Mapping	Optional
Value Range	Unsigned16
Default Value	FFFF

to

Sub-Index	FE _h
Description	Filter Mask Output FE0 _h to FF0 _h
Access	rw
Entry Category	Optional
PDO Mapping	Optional
Value Range	Unsigned16
Default Value	FFFF _h

8.2.17 Write Output 32-Bit (6320_h)

This object shall set a group of 32 output lines as 4-Byte information. A maximum of 255 x 32-Bit words is addressable (8160 outputs).

Object Description

INDEX	6320 _h
Name	Write Output 32-Bit
Object Code	Array
Data Type	Unsigned32
Category	Optional

Entry Description

Sub-Index	0 _h
Description	Number of Outputs 32-Bit
Access	ro
Entry Category	Mandatory
PDO Mapping	No
Value Range	1 _h to FE _h
Default Value	No

Sub-Index	1 _h
Description	Write Output 1 _h to 20 _h
Access	rw
Entry Category	Mandatory
PDO Mapping	Optional
Value Range	Unsigned32
Default Value	0 _h

Sub-Index	2 _h
Description	Write Output 21 _h to 40 _h
Data Type	Unsigned32
Access	rw
Entry Category	Optional
PDO Mapping	Optional
Value Range	Unsigned32
Default Value	0 _h

to

Sub-Index	FE _h
Description	Write Output 1FC0 _h to 1FE0 _h
Data Type	Unsigned32
Access	rw
Entry Category	Optional
PDO Mapping	Optional
Value Range	Unsigned32
Default Value	0 _h

8.2.21 Change Polarity Output 32-Bit (6322_h)

This object shall define the polarity for a group of 32 output lines. Output polarity can be inverted individually.

1 = enabled 0 = disabled

If the object is not supported the device shall behave accordingly to the default value.

Object Description

INDEX	6322 _h
Name	Change Polarity Output 32-Bit
Object Code	Array
Data Type	Unsigned32
Category	Optional

Entry Description

Sub-Index	0 _h
Description	Number of Outputs 32-Bit
Access	ro
Entry Category	Mandatory
PDO Mapping	No
Value Range	1 _h to FE _h
Default Value	No

Sub-Index	1 _h
Description	Polarity Output 1 _h to 20 _h
Access	rw
Entry Category	Mandatory
PDO Mapping	No
Value Range	Unsigned32
Default Value	0 _h

Sub-Index	2 _h
Description	Polarity Output 21 _h to 40 _h
Access	rw
Entry Category	Optional
PDO Mapping	Optional
Value Range	Unsigned32
Default Value	0 _h

to

Sub-Index	FE _h
Description	Polarity Output 1FC0 _h to 1FE0 _h
Access	rw
Entry Category	Optional
PDO Mapping	Optional
Value Range	Unsigned32
Default Value	0 _h

8.2.22 Error Mode Output 32-Bit (6326_h)

These objects indicate, whether an output is set to a pre-defined error value (see also 6327_h object) in case of an internal device failure a 'Stop Remote Node' indication.

1 = output value shall take the pre-defined condition as specified in 6327_h object

0 = output value shall be kept if an error occurs

If the object is not supported, the device shall behave accordingly to the default value.

Object Description

INDEX	6326 _h
Name	Error Mode Output 32-Bit
Object Code	Array
Data Type	Unsigned32
Category	Optional

Entry Description

Sub-Index	0 _h
Description	Number of Outputs 32-Bit
Access	ro
Entry Category	Mandatory
PDO Mapping	No
Value Range	1 _h to FE _h
Default Value	No

Sub-Index	1 _h
Description	Error Mode Output 1 _h to 20 _h
Access	rw
Entry Category	Mandatory
PDO Mapping	Optional
Value Range	Unsigned32
Default Value	FFFF FFFF _h

Sub-Index	2 _h
Description	Error Mode Output 21 _h to 40 _h
Access	rw
Entry Category	Optional
PDO Mapping	Optional
Value Range	Unsigned32
Default Value	FFFF FFFF _h

to

Sub-Index	FE _h
Description	Error Mode Output 1FC0 _h to 1FE0 _h
Access	rw
Entry Category	Optional
PDO Mapping	Optional
Value Range	Unsigned32
Default Value	FFFF FFFF _h

8.2.23 Error Value Output 32-Bit (6327_h)

On condition that the corresponding Error Mode is active, device failures (see chapter 5.2) shall set the outputs to the value configured by this object.

0 = Output shall be set to '0' in case of fault, if 6326_h object is enabled

1 = Output shall be set to '1' in case of fault, if 6326_h object is enabled

If the object is not supported, the device shall behave accordingly to the default value.

Object Description

INDEX	6327 _h
Name	Error Value Output 32-Bit
Object Code	Array
Data Type	Unsigned32
Category	Optional

Entry Description

Sub-Index	0 _h
Description	Number of Outputs 32-Bit
Access	ro
Entry Category	Mandatory
PDO Mapping	No
Value Range	1 _h to FE _h
Default Value	No

Sub-Index	1 _h
Description	Error Value Output 1 _h to 20 _h
Access	rw
Entry Category	Mandatory
PDO Mapping	Optional
Value Range	Unsigned32
Default Value	0 _h

Sub-Index	2 _h
Description	Error Value Output 21 _h to 40 _h
Access	rw
Entry Category	Optional
PDO Mapping	Optional
Value Range	Unsigned32
Default Value	0 _h

to

Sub-Index	FE _h
Description	Error Value Output 1FC0 _h to 1FE0 _h
Access	rw
Entry Category	Optional
PDO Mapping	Optional
Value Range	Unsigned32
Default Value	0 _h

8.2.24 Filter Mask Output 32-Bit (6328_h)

This object defines an additional configurable output filter mask for a group of 32 outputs.

1 = output shall be set to the received output value

0 = don't care the received output value is neglected for the appropriated output channel, the old output value shall be kept.

If the object is not supported, the device shall behave accordingly to the default value.

Object Description

INDEX	6328 _h
Name	Filter Mask Output 32-Bit
Object Code	Array
Data Type	Unsigned32
Category	Optional

Entry Description

Sub-Index	0 _h
Description	Number of Outputs 32-Bit
Access	ro
Entry Category	Mandatory
PDO Mapping	No
Value Range	1 _h to FE _h
Default Value	No

Sub-Index	1 _h
Description	Filter Mask Output 1 _h to 20 _h
Access	rw
Entry Category	Mandatory
PDO Mapping	Optional
Value Range	Unsigned32
Default Value	FFFF FFFF _h

Sub-Index	2 _h
Description	Filter Mask Output 21 _h to 40 _h
Data Type	Unsigned32
Access	rw
Entry Category	Optional
PDO Mapping	Optional
Value Range	Unsigned32
Default Value	FFFF FFFF _h

to

Sub-Index	Fe _h
Description	Filter Mask Output 1FC0 _h to 1FE0 _h
Data Type	Unsigned32
Access	rw
Entry Category	Optional
PDO Mapping	Optional
Value Range	Unsigned32
Default Value	FFFF FFFF _h

8.3 Analogue input module

8.3.1 Read Analogue Input 8-Bit (6400_h)

This object shall read the value of the input channel 'n'. Value is 8-Bit or less in size. The value shall be always left adjusted. The remaining bits at the right side of the LSB shall be set to zero.

Object Description

INDEX	6400 _h
Name	Read Analogue Input 8-Bit
Object Code	Array
Data Type	Integer8
Category	Optional

Entry Description

Sub-Index	0 _h
Description	Number of Analogue Inputs 8-Bit
Access	ro
Entry Category	Mandatory
PDO Mapping	No
Value Range	1 _h to FE _h
Default Value	No

Sub-Index	1 _h
Description	Analogue Input 1
Access	ro
Entry Category	Mandatory
PDO Mapping	Optional
Value Range	Integer8
Default Value	No

Sub-Index	2 _h
Description	Analogue Input 2
Access	ro
Entry Category	Optional
PDO Mapping	Optional
Value Range	Integer8
Default Value	No

to

Sub-Index	FE _h
Description	Analogue Input 254
Access	ro
Entry Category	Optional
PDO Mapping	Optional
Value Range	Integer8
Default Value	No

8.3.2 Read Analogue Input 16-Bit (6401_h)

This object shall read the value of the input channel 'n'. Value is 16-Bit wide or less. The value shall be always left adjusted. The remaining bits at the right side of the LSB shall be set to zero.

Object Description

INDEX	6401 _h
Name	Read Analogue Input 16-Bit
Object Code	Array
Data Type	Integer16
Category	Conditional: Device with analog input

Entry Description

Sub-Index	0 _h
Description	Number of Analogue Inputs 16-Bit
Access	ro
Entry Category	Mandatory
PDO Mapping	No
Value Range	1 _h to FE _h
Default Value	No

Sub-Index	1 _h
Description	Analogue Input 1
Access	ro
Entry Category	Mandatory
PDO Mapping	Default
Value Range	Integer16
Default Value	No

Sub-Index	2 _h
Description	Analogue Input 2
Access	ro
Entry Category	Optional
PDO Mapping	Default
Value Range	Integer16
Default Value	No

to

Sub-Index	0C _h
Description	Analogue Input 12
Access	ro
Entry Category	Optional
PDO Mapping	Default
Value Range	Integer
Default Value	No

Sub-Index	0D _h
Description	Analogue Input 13
Access	ro
Entry Category	Optional
PDO Mapping	Optional
Value Range	Integer16
Default Value	No

to

Sub-Index	FE _h
Description	Analogue Input 254
Access	ro
Entry Category	Optional
PDO Mapping	Optional
Value Range	Integer16
Default Value	No

8.3.3 Read Analogue Input 32-Bit (6402_h)

This object shall read the value of the input channel 'n'. Value is 32-Bit wide or less. The value shall be always left adjusted. The remaining bits at the right side of the LSB shall be set to zero.

Object Description

INDEX	6402 _h
Name	Read Analogue Input 32-Bit
Object Code	Array
Data Type	Integer32
Category	Optional

Entry Description

Sub-Index	0 _h
Description	Number of Analogue Inputs 32-Bit
Access	ro
Entry Category	Mandatory
PDO Mapping	No
Value Range	1 _h to FE _h
Default Value	No

Sub-Index	1 _h
Description	Analogue Input 1
Access	ro
Entry Category	Mandatory
PDO Mapping	Optional
Value Range	Integer32
Default Value	No

Sub-Index	2 _h
Description	Analogue Input 2
Access	ro
Entry Category	Optional
PDO Mapping	Optional
Value Range	Integer32
Default Value	No

to

Sub-Index	FE _h
Description	Analogue Input 254
Access	ro
Entry Category	Optional
PDO Mapping	Optional
Value Range	Integer32
Default Value	No

8.3.4 Read Analogue Input Float (6403_h)

This object shall read the Float value of the input channel 'n'.

Float value = Integer value x Input scale + Offset value

Object Description

INDEX	6403 _h
Name	Read Analogue Input Float
Object Code	Array
Data Type	Float
Category	Optional

Entry Description

Sub-Index	0 _h
Description	Number of Analogue Inputs Float
Access	ro
Entry Category	Mandatory
PDO Mapping	No
Value Range	1 _h to FE _h
Default Value	No

Sub-Index	1 _h
Description	Analogue Input 1
Access	ro
Entry Category	Mandatory
PDO Mapping	Optional
Value Range	Float
Default Value	No

Sub-Index	2 _h
Description	Analogue Input 2
Access	ro
Entry Category	Optional
PDO Mapping	Optional
Value Range	Float
Default Value	No

to

Sub-Index	FE _h
Description	Analogue Input 254
Access	ro
Entry Category	Optional
PDO Mapping	Optional
Value Range	Float
Default Value	No

8.3.5 Read Manufacturer-specific Analogue Input (6404_h)

This object shall read the manufacturer-specific value of the input channel 'n'.

Object Description

INDEX	6404 _h
Name	Read Manufacturer Specific Analogue Input
Object Code	Array
Data Type	Manufacturer-specific
Category	Optional

Entry Description

Sub-Index	0 _h
Description	Number of Analogue Inputs
Access	ro
Entry Category	Mandatory
PDO Mapping	No
Value Range	1 _h to FE _h
Default Value	No

Sub-Index	1 _h
Description	Analogue Input 1
Access	ro
Entry Category	Mandatory
PDO Mapping	Optional
Value Range	Manufacturer-specific
Default Value	No

Sub-Index	2 _h
Description	Analogue Input 2
Access	ro
Entry Category	Optional
PDO Mapping	Optional
Value Range	Manufacturer-specific
Default Value	No

to

Sub-Index	FE _h
Description	Analogue Input 254
Access	ro
Entry Category	Optional
PDO Mapping	Optional
Value Range	Manufacturer-specific
Default Value	No

8.4 Analogue output module

8.4.1 Write Analogue Output 8-Bit (6410_h)

This object shall write an Integer8 value to the output channel 'n'. The value shall be always left adjusted.

Object Description

INDEX	6410 _h
Name	Write Analogue Output 8-Bit
Object Code	Array
Data Type	Integer8
Category	Optional

Entry Description

Sub-Index	0 _h
Description	Number of Analogue Outputs 8-Bit
Access	ro
Entry Category	Mandatory
PDO Mapping	No
Value Range	1 _h to FE _h
Default Value	No

Sub-Index	1 _h
Description	Analogue Output 1
Access	rw
Entry Category	Mandatory
PDO Mapping	Optional
Value Range	Integer8
Default Value	0 _h

Sub-Index	2 _h
Description	Analogue Output 2
Access	rw
Entry Category	Optional
PDO Mapping	Optional
Value Range	Integer8
Default Value	0 _h

to

Sub-Index	FE _h
Description	Analogue Output 254
Access	rw
Entry Category	Optional
PDO Mapping	Optional
Value Range	Integer8
Default Value	0 _h

8.4.2 Write Analogue Output 16-Bit (6411_h)

This object shall write an Integer16 value to the output channel 'n'. The value shall be always left adjusted.

Object Description

INDEX	6411 _h
Name	Write Analogue Output 16-Bit
Object Code	Array
Data Type	Integer16
Category	Conditional: Device with analogue output

Entry Description

Sub-Index	0 _h
Description	Number of Analogue Outputs 16-Bit
Access	ro
Entry Category	Mandatory
PDO Mapping	No
Value Range	1 _h to FE _h
Default Value	No

Sub-Index	1 _h
Description	Analogue Output 1
Access	rw
Entry Category	Mandatory
PDO Mapping	Default
Value Range	Integer16
Default Value	0 _h

Sub-Index	2 _h
Description	Analogue Output 2
Access	rw
Entry Category	Optional
PDO Mapping	Default
Value Range	Integer
Default Value	0 _h

to

Sub-Index	0C _h
Description	Analogue Output 12
Access	rw
Entry Category	Optional
PDO Mapping	Default
Value Range	Integer16
Default Value	0 _h

Sub-Index	0D _h
Description	Analogue Output 13
Access	rw
Entry Category	Optional
PDO Mapping	Optional
Value Range	Integer16
Default Value	0 _h

to

Sub-Index	FE _h
Description	Analogue Output 254
Access	rw
Entry Category	Optional
PDO Mapping	Optional
Value Range	Integer16
Default Value	0 _h

8.4.3 Write Analogue Output 32-Bit (6412_h)

This object shall write an Integer32 value to the output channel 'n'. The value shall be always left adjusted.

Object Description

INDEX	6412 _h
Name	Write Analogue Output 32-Bit
Object Code	Array
Data Type	Integer32
Category	Optional

Entry Description

Sub-Index	0 _h
Description	Number of Analogue Outputs 32-Bit
Access	ro
Entry Category	Mandatory
PDO Mapping	No
Value Range	1 _h to FE _h
Default Value	No

Sub-Index	1 _h
Description	Analogue Output 1
Access	rw
Entry Category	Mandatory
PDO Mapping	Optional
Value Range	Integer32
Default Value	0 _h

Sub-Index	2 _h
Description	Analogue Output 2
Access	rw
Entry Category	Optional
PDO Mapping	Optional
Value Range	Integer32
Default Value	0 _h

to

Sub-Index	FE _h
Description	Analogue Output 254
Access	rw
Entry Category	Optional
PDO Mapping	Optional
Value Range	Integer32
Default Value	0 _h

8.4.4 Write Analogue Output Float (6413_h)

This object shall write the Float value to the output channel 'n'.

$$\text{Integer value} = \frac{\text{Float value} - \text{Output offset}}{\text{Output scale}}$$

Object Description

INDEX	6413 _h
Name	Write Analogue Output Float
Object Code	Array
Data Type	Float
Category	Optional

Entry Description

Sub-Index	0 _h
Description	Number of Analogue Outputs Float
Access	ro
Entry Category	Mandatory
PDO Mapping	No
Value Range	1 _h to FE _h
Default Value	No

Sub-Index	1 _h
Description	Analogue Output 1
Access	rw
Entry Category	Mandatory
PDO Mapping	Optional
Value Range	Float
Default Value	0.0

Sub-Index	2 _h
Description	Analogue Output 2
Access	rw
Entry Category	Optional
PDO Mapping	Optional
Value Range	Float
Default Value	0.0

to

Sub-Index	FE _h
Description	Analogue Output 254
Access	rw
Entry Category	Optional
PDO Mapping	Optional
Value Range	Float
Default Value	0.0

8.4.5 Write Manufacturer-specific Analogue Output (6414_h)

Writes the manufacturer-specific value to the output channel 'n'.

Object Description

INDEX	6414 _h
Name	Write Manufacturer Specific Analogue Output
Object Code	Record or Array
Data Type	Manufacturer-specific
Category	Optional

Entry Description

Sub-Index	0 _h
Description	Number of Analogue Outputs
Access	ro
Entry Category	Mandatory
PDO Mapping	No
Value Range	1 _h to FE _h
Default Value	No

Sub-Index	1 _h
Description	Analogue Output 1
Access	rw
Entry Category	Mandatory
PDO Mapping	Optional
Value Range	Manufacturer-specific
Default Value	Manufacturer-specific

Sub-Index	2 _h
Description	Analogue Output 2
Access	rw
Entry Category	Optional
PDO Mapping	Optional
Value Range	Manufacturer-specific
Default Value	Manufacturer-specific

to

Sub-Index	FE _h
Description	Analogue Output 254
Access	rw
Entry Category	Optional
PDO Mapping	Optional
Value Range	Manufacturer-specific
Default Value	Manufacturer-specific

8.5 Analogue input set-ups

8.5.1 (6420_h)

Reserved for compatibility reason.

8.5.2 Analogue Input Interrupt Trigger Selection (6421_h)

This object determines, which events shall cause an interrupt for a specific channel. Bits set in the list below shall refer to ways in which interrupts may be triggered. If the object is not supported, the device shall behave accordingly to the default value.

Bit no.	Interrupt trigger
0	Upper limit exceeded
1	Input below lower limit
2	Input changed by more than delta
3	Input reduced by more than negative delta
4	Input increased by more than positive delta
5 to 7	reserved for future use.

Object Description

INDEX	6421 _h
Name	Interrupt Trigger Selection
Object Code	Array
Data Type	Unsigned8
Category	Optional

Entry Description

Sub-Index	0 _h
Description	Number of Analogue Inputs
Access	ro
Entry Category	Mandatory
PDO Mapping	No
Value Range	1 _h to FE _h
Default Value	No

Sub-Index	1 _h
Description	Analogue Input 1 _h
Access	rw
Entry Category	Mandatory
PDO Mapping	Optional
Value Range	See above
Default Value	7 _h

Sub-Index	2 _h
Description	Analogue Input 2 _h
Access	rw
Entry Category	Optional
PDO Mapping	Optional
Value Range	See above
Default Value	7 _h

to

Sub-Index	FE _h
Description	Analogue Input FE _h
Access	rw
Entry Category	Optional
PDO Mapping	Optional
Value Range	See above
Default Value	7 _h

8.5.3 Analogue Input Interrupt Source (6422_h)

This object shall determine, which channel has produced an interrupt. Bits set shall relate to the number of any channels that have produced interrupts. The bits shall be reset automatically after read by SDO or transmitted by means of a PDO.

1 = interrupt produced

0 = no interrupt produced

If the object is not supported, the device shall behave accordingly to the default value.

Object Description

INDEX	6422 _h
Name	Analogue Input Interrupt Source
Object Code	Array
Data Type	Unsigned32
Category	Optional

Entry Description

Sub-Index	0 _h
Description	Number of Interrupt Source Banks
Access	ro
Entry Category	Mandatory
PDO Mapping	No
Value Range	1 _h to 8 _h
Default Value	No

Sub-Index	1 _h
Description	Interrupt Source Bank 1
Access	ro
Entry Category	Mandatory
PDO Mapping	Optional
Value Range	Unsigned32
Default Value	0 _h

Sub-Index	2 _h
Description	Interrupt Source Bank 2
Access	ro
Entry Category	Optional
PDO Mapping	Optional
Value Range	Unsigned32
Default Value	0 _h

to

Sub-Index	8 _h
Description	Interrupt Source Bank 8
Access	ro
Entry Category	Optional
PDO Mapping	Optional
Value Range	Unsigned32
Default Value	0 _h

8.5.4 Analogue Input Global Interrupt Enable (6423_h)

This object shall enable and disable globally the interrupt behaviour without changing the interrupt mask. By default, no analogue input activates an interrupt.

TRUE = global interrupt enabled

FALSE = global interrupt disabled

Object Description

INDEX	6423 _h
Name	Analogue Input Global Interrupt Enable
Object Code	Var
Data Type	Boolean
Category	Conditional: Device with analogue input

Entry Description

Sub-Index	0 _h
Access	rw
PDO Mapping	Optional
Value Range	Boolean
Default Value	FALSE

8.5.5 Analogue Input Interrupt Upper Limit Integer (6424_h)

If enabled (see 6423_h object), an interrupt is triggered when the analogue input is equal or rises above the given value. The value shall be always left adjusted. As long as the trigger condition is met, every change of the analogue input data generates a new interrupt, if there is no additional trigger condition, e.g. an input interrupt delta (6426_h).

If the object is not supported, the device shall behave accordingly to the default value.

Note: Configuration of the Analogue Input Interrupt Upper Limit Float object (6429_h) shall cause also value change in 6424_h object and vice versa.

Object Description

INDEX	6424 _h
Name	Analogue Input Interrupt Upper Limit Integer
Object Code	Array
Data Type	Integer32
Category	Optional

Entry Description

Sub-Index	0 _h
Description	Number of Analogue Inputs
Access	ro
Entry Category	Manadatory
PDO Mapping	No
Value Range	1 _h to FE _h
Default	No

Sub-Index	1 _h
Description	Analogue Input 1
Access	rw
Entry Category	Mandatory
PDO Mapping	Optional
Value Range	Integer32
Default Value	0 _h

Sub-Index	2 _h
Description	Analogue Input 2
Access	rw
Entry Category	Optional
PDO Mapping	Optional
Value Range	Integer32
Default Value	0 _h

to

Sub-Index	FE _h
Description	Analogue Input 254
Access	rw
Entry Category	Optional
PDO Mapping	Optional
Value Range	Integer32
Default Value	0 _h

8.5.6 Analogue Input Interrupt Lower Limit Integer (6425_h)

If enabled (see 6423_h object), an interrupt is triggered when the analogue input falls below the given value. The value shall be always left adjusted. As long as the trigger condition is met, every change of the analogue input data generates a new interrupt, if there is no additional trigger condition, e.g. an input interrupt delta (6426_h).

If the object is not supported, the device shall behave accordingly to the default value.

Note: Configuration of the Analogue Input Interrupt Lower Limit Float object (642A_h) shall cause also value change in 6425_h object and vice versa.

Object Description

INDEX	6425 _h
Name	Analogue Input Interrupt Lower Limit Integer
Object Code	Array
Data Type	Integer32
Category	Optional

Entry Description

Sub-Index	0 _h
Description	Number of Analogue Inputs
Access	ro
Entry Category	Mandatory
PDO Mapping	No
Value Range	1 _h to FE _h
Default Value	No

Sub-Index	1 _h
Description	Analogue Input 1
Access	rw
Entry Category	Optional
PDO Mapping	Optional
Value Range	Integer32
Default Value	0 _h

Sub-Index	2 _h
Description	Analogue Input 2
Access	rw
Entry Category	Optional
PDO Mapping	Optional
Value Range	Integer32
Default Value	0 _h

to

Sub-Index	FE _h
Description	Analogue Input 254
Access	rw
Entry Category	Optional
PDO Mapping	Optional
Value Range	Integer32
Default Value	0 _h

8.5.7 Analogue Input Interrupt Delta Unsigned (6426_h)

This object shall set the delta value (rising or falling above or below the last communicated value) for interrupt-enabled analogue inputs (see 6423_h object).

If the object is not supported, the device shall behave accordingly to the default value.

Note: Configuration of the Analogue Input Interrupt Delta Float object (642B_h) shall cause also value change in 6426_h object and vice versa.

Object Description

INDEX	6426 _h
Name	Analogue Input Interrupt Delta Unsigned
Object Code	Array
Data Type	Unsigned32
Category	Optional

Entry Description

Sub-Index	0 _h
Description	Number of Analogue Inputs
Access	ro
Entry Category	Mandatory
PDO Mapping	No
Value Range	1 _h to FE _h
Default Value	No

Sub-Index	1 _h
Description	Analogue Input 1
Access	rw
Entry Category	Mandatory
PDO Mapping	Optional
Value Range	Unsigned32
Default Value	0 _h

Sub-Index	2 _h
Description	Analogue Input 2
Access	rw
Entry Category	Optional
PDO Mapping	Optional
Value Range	Unsigned32
Default Value	0 _h

to

Sub-Index	FE _h
Description	Analogue Input 254
Access	rw
Entry Category	Optional
PDO Mapping	Optional
Value Range	Unsigned32
Default Value	0 _h

8.5.8 Analogue Input Interrupt Negative Delta Unsigned (6427_h)

This object shall set the negative delta value (falling below the last communicated value) for interrupt-enabled analogue inputs (see 6423_h object).

If the object is not supported, the device shall behave accordingly to the default value.

Note: Configuration of the Analogue Input Interrupt Negative Delta Float object (642C_h) shall cause also value change in 6427_h object and vice versa.

Object Description

INDEX	6427 _h
Name	Analogue Input Interrupt Negative Delta Unsigned
Object Code	Array
Data Type	Unsigned32
Category	Optional

Entry Description

Sub-Index	0 _h
Description	Number of Analogue Inputs
Access	ro
Entry Category	Mandatory
PDO Mapping	No
Value Range	1 _h to FE _h
Default Value	No

Sub-Index	1 _h
Description	Analogue Input 1
Access	rw
Entry Category	Manadatory
PDO Mapping	Optional
Value Range	Unsigned32
Default Value	0 _h

Sub-Index	2 _h
Description	Analogue Input 2
Access	rw
Entry Category	Optional
PDO Mapping	Optional
Value Range	Unsigned32
Default Value	0 _h

to

Sub-Index	FE _h
Description	Analogue Input 254
Access	rw
Entry Category	Optional
PDO Mapping	Optional
Value Range	Unsigned32
Default Value	0 _h

8.5.9 Analogue Input Interrupt Positive Delta Unsigned (6428_h)

This object shall set the positive delta value (rising above the last communicated value) for interrupt-enabled analogue inputs (see 6423_h object).

If the object is not supported, the device shall behave accordingly to the default value.

Note: Configuration of the Analogue Input Interrupt Positive Delta Float object (642D_h) shall cause also value change in 6428_h object and vice versa.

Object Description

INDEX	6428 _h
Name	Analogue Input Interrupt Positive Delta Unsigned
Object Code	Array
Data Type	Unsigned32
Category	Optional

Entry Description

Sub-Index	0 _h
Description	Number of Analogue Inputs
Access	ro
Entry Category	Mandatory
PDO Mapping	No
Value Range	1 _h to FE _h
Default Value	No

Sub-Index	1 _h
Description	Analogue Input 1
Access	rw
Entry Category	Mandatory
PDO Mapping	Optional
Value Range	Unsigned32
Default Value	0 _h

Sub-Index	2 _h
Description	Analogue Input 2
Access	rw
Entry Category	Optional
PDO Mapping	Optional
Value Range	Unsigned32
Default Value	0 _h

to

Sub-Index	FE _h
Description	Analogue Input 254
Access	rw
Entry Category	Optional
PDO Mapping	Optional
Value Range	Unsigned32
Default Value	0 _h

8.5.10 Analogue Input Interrupt Upper Limit Float (6429_h)

This object shall set the converted upper limits for interrupt-enabled analogue inputs (see 6423_h object). As long as the trigger condition is met, every change of the analogue input data generates a new interrupt, if there is no additional trigger condition, e.g. an input interrupt delta (642B_h).

If the object is not supported, the device shall behave accordingly to the default value.

Note: Configuration of the Analogue Input Interrupt Upper Limit Integer object (6424_h) shall cause also value change in 6429_h object and vice versa.

Object Description

INDEX	6429 _h
Name	Analogue Input Interrupt Upper Limit Float
Object Code	Array
Data Type	Float
Category	Optional

Entry Description

Sub-Index	0 _h
Description	Number of Analogue Inputs
Access	ro
Entry Category	Mandatory
PDO Mapping	No
Value Range	1 _h to FE _h
Default Value	No

Sub-Index	1 _h
Description	Analogue Input 1
Access	rw
Entry Category	Mandatory
PDO Mapping	Optional
Value Range	Float
Default Value	0.0

Sub-Index	2 _h
Description	Analogue Input 2
Access	rw
Entry Category	Optional
PDO Mapping	Optional
Value Range	Float
Default Value	0.0

to

Sub-Index	FE _h
Description	Analogue Input 254
Access	rw
Entry Category	Optional
PDO Mapping	Optional
Value Range	Float
Default Value	0.0

8.5.11 Analogue Input Interrupt Lower Limit Float (642A_h)

This object shall set the lower limits for interrupt-enabled analogue inputs (see 6423_h object). As long as the trigger condition is met, every change of the analogue input data generates a new interrupt, if there is no additional trigger condition, e.g. an input interrupt delta (642B_h).

If the object is not supported, the device shall behave accordingly to the default value.

Note: Configuration of the Analogue Input Interrupt Lower Limit Integer object (6425_h) shall cause also value change in 642A_h object and vice versa.

Object Description

INDEX	642A _h
Name	Analogue Input Interrupt Lower Limit Float
Object Code	Array
Data Type	Float
Category	Optional

Entry Description

Sub-Index	0 _h
Description	Number Analogue Inputs
Access	ro
Entry Category	Mandatory
PDO Mapping	No
Value Range	1 _h to FE _h
Default Value	No

Sub-Index	1 _h
Description	Analogue Input 1
Access	rw
Entry Category	Mandatory
PDO Mapping	Optional
Value Range	Float
Default Value	0.0

Sub-Index	2 _h
Description	Analogue Input 2
Access	rw
Entry Category	Optional
PDO Mapping	Optional
Value Range	Float
Default Value	0.0

to

Sub-Index	FE _h
Description	Analogue Input 254
Access	rw
Entry Category	Optional
PDO Mapping	Optional
Value Range	Float
Default Value	0.0

8.5.12 Analogue Input Interrupt Delta Float (642B_h)

This object shall set the delta value (rising or falling above or below the last sample) in Float format for interrupt-enabled analogue inputs (see 6423_h object).

If the object is not supported, the device shall behave accordingly to the default value.

Note: Configuration of the Analogue Input Interrupt Delta Unsigned object (6426_h) shall cause also value change in 642B_h object and vice versa.

Object Description

INDEX	642B _h
Name	Analogue Input Interrupt Delta Float
Object Code	Array
Data Type	Float
Catagory	Optional

Entry Description

Sub-Index	0 _h
Description	Number of Analogue Inputs
Access	ro
Entry Category	Mandatory
PDO Mapping	No
Value Range	1 _h to FE _h
Default Value	No

Sub-Index	1 _h
Description	Analogue Input 1
Access	rw
Entry Category	Mandatory
PDO Mapping	Optional
Value Range	Float
Default Value	0.0

Sub-Index	2 _h
Description	Analogue Input 2
Access	rw
Entry Category	Optional
PDO Mapping	Optional
Value Range	Float
Default Value	0.0

to

Sub-Index	FE _h
Description	Analogue Input 254
Access	rw
Entry Category	Optional
PDO Mapping	Optional
Value Range	Float
Default Value	0.0

8.5.13 Analogue Input Interrupt Negative Delta Float (642C_h)

This object shall set the negative delta value (falling below the last sample) in Float format for interrupt-enabled analogue inputs (see 6423_h object).

If the object is not supported, the device shall behave accordingly to the default value.

Note: Configuration of the Analogue Input Interrupt Negative Delta Unsigned object (6427_h) shall cause also value change in 642C_h object and vice versa.

Object Description

INDEX	642C _h
Name	Analogue Input Interrupt Negative Delta Float
Object Code	Array
Data Type	Float
Category	Optional

Entry Description

Sub-Index	0 _h
Description	Number of Analogue Inputs
Access	ro
Entry Category	Mandatory
PDO Mapping	No
Value Range	1 _h to FE _h
Default Value	No

Sub-Index	1 _h
Description	Analogue Input 1
Access	rw
Entry Category	Mandatory
PDO Mapping	Optional
Value Range	Float
Default Value	0.0

Sub-Index	2 _h
Description	Analogue Input 2
Access	rw
Entry Category	Optional
PDO Mapping	Optional
Value Range	Float
Default Value	0.0

to

Sub-Index	FE _h
Description	Analogue Input 254
Access	rw
Entry Category	Optional
PDO Mapping	Optional
Value Range	Float
Default Value	0.0

8.5.14 Analogue Input Interrupt Positive Delta Float (642D_h)

This object shall set the positive delta value (rising above the last sample) in Float format for interrupt-enabled analogue inputs (see 6423_h object).

If the object is not supported, the device shall behave accordingly to the default value.

Note: Configuration of the Analogue Input Interrupt Positive Delta Unsigned object (6428_h) shall cause also value change in 642D_h object and vice versa.

Object Description

INDEX	642D _h
Name	Analogue Input Interrupt Positive Delta Float
Object Code	Array
Data Type	Float
Category	Optional

Entry Description

Sub-Index	0 _h
Description	Number of Analogue Inputs
Access	ro
Entry Category	Mandatory
PDO Mapping	No
Value Range	1 _h to FE _h
Default Value	No

Sub-Index	1 _h
Description	Analogue Input 1
Access	rw
Entry Category	Mandatory
PDO Mapping	Optional
Value Range	Float
Default Value	0.0

Sub-Index	2 _h
Description	Analogue Input 2
Access	rw
Entry Category	Optional
PDO Mapping	Optional
Value Range	Float
Default Value	0.0

to

Sub-Index	FE _h
Description	Analogue Input 254
Access	rw
Entry Category	Optional
PDO Mapping	Optional
Value Range	Float
Default Value	0.0

8.5.15 Analogue Input Offset Float (642E_h)

This object shall set the offsets in Float format for input data (6403_h object) for channel 'n'.

If the object is not supported, the device shall behave accordingly to 6431_h object, or if that object is also not supported, the device shall behave accordingly to the default value.

Note: Configuration of the Analogue Input Offset Integer object (6431_h) shall cause also value change in 642E_h object and vice versa.

Object Description

INDEX	642E _h
Name	Analogue Input Offset Float
Object Code	Array
Data Type	Float
Category	Optional

Entry Description

Sub-Index	0 _h
Description	Number of Analogue Inputs
Access	ro
Entry Category	Mandatory
PDO Mapping	No
Value Range	1 _h to FE _h
Default Value	No

Sub-Index	1 _h
Description	Analogue Input 1
Access	rw
Entry Category	Mandatory
PDO Mapping	Optional
Value Range	Float
Default Value	0.0

Sub-Index	2 _h
Description	Analogue Input 2
Access	rw
Entry Category	Optional
PDO Mapping	Optional
Value Range	Float
Default Value	0.0

to

Sub-Index	FE _h
Description	Analogue Input 254
Access	rw
Entry Category	Optional
PDO Mapping	Optional
Value Range	Float
Default Value	0.0

8.5.16 Analogue Input Scaling Float (642F_h)

This object shall set the scaling in Float format for input data (6403_h object).

If the object is not supported, the device shall behave accordingly to 6432_h object, or if that object is also not supported, the device shall behave accordingly to the default value.

Note: Configuration of the Analogue Input Scaling Integer object (6432_h) shall cause also value change in 642F_h object and vice versa.

Object Description

INDEX	642F _h
Name	Analogue Input Scaling Float
Object Code	Array
Data Type	Float
Category	Optional

Entry Description

Sub-Index	0 _h
Description	Number of Analogue Inputs
Access	ro
Entry Category	Mandatory
PDO Mapping	No
Value Range	1 _h to FE _h
Default Value	No

Sub-Index	1 _h
Description	Analogue Input 1
Access	rw
Entry Category	Mandatory
PDO Mapping	Optional
Value Range	Float
Default Value	1.0

Sub-Index	2 _h
Description	Analogue Input 2
Access	rw
Entry Category	Optional
PDO Mapping	Optional
Value Range	Float
Default Value	1.0

to

Sub-Index	FE _h
Description	Analogue Input 254
Access	rw
Entry Category	Optional
PDO Mapping	Optional
Value Range	Float
Default Value	1.0

8.5.17 Analogue Input SI Unit (6430_h)

This object shall assign SI units and prefixes for analogue inputs. The structure of the SI unit entry shall be as followed:

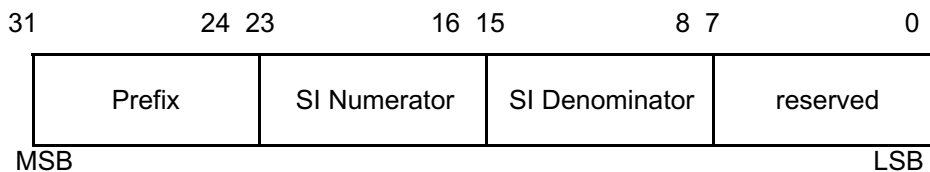

The values for prefix, SI numerator, and SI denominator are specified in /3/.

Object Description

INDEX	6430 _h
Name	Analogue Input SI Unit
Object Code	Array
Data Type	Unsigned32
Category	Optional

Entry Description

Sub-Index	0 _h
Description	Number of Analogue Inputs
Access	ro
Entry Category	Mandatory
PDO Mapping	No
Value Range	1 _h to FE _h
Default Value	No

Sub-Index	1 _h
Description	Analogue Input 1
Access	rw
Entry Category	Mandatory
PDO Mapping	Optional
Value Range	Unsigned32
Default Value	No

Sub-Index	2 _h
Description	Analogue Input 2
Access	rw
Entry Category	Optional
PDO Mapping	Optional
Value Range	Unsigned32
Default Value	No

to

Sub-Index	FE _h
Description	Analogue Input 254
Access	rw
Entry Category	Optional
PDO Mapping	Optional
Value Range	Unsigned32
Default Value	No

8.5.18 Analogue Input Offset Integer (6431_h)

This object shall set the offset in Integer format for input data (6403_h object).

If the object is not supported, the device shall behave accordingly to 642E_h object, or if that object is also not supported, the device shall behave accordingly to the default value.

Note: Configuration of the Analogue Input Offset Float object (642E_h) shall cause also value change in 6431_h object and vice versa.

Object Description

INDEX	6431 _h
Name	Analogue Input Offset Integer
Object Code	Array
Data Type	Integer32
Category	Optional

Entry Description

Sub-Index	0 _h
Description	Number of Analogue Inputs
Access	ro
Entry Category	Mandatory
PDO Mapping	No
Value Range	1 _h to FE _h
Default Value	No

Sub-Index	1 _h
Description	Analogue Input 1
Access	rw
Entry Category	Mandatory
PDO Mapping	Optional
Value Range	Integer32
Default Value	0 _h

Sub-Index	2 _h
Description	Analogue Input 2
Access	rw
Entry Category	Optional
PDO Mapping	Optional
Value Range	Integer32
Default Value	0 _h

to

Sub-Index	FE _h
Description	Analogue Input 254
Access	rw
Entry Category	Optional
PDO Mapping	Optional
Value Range	Integer32
Default Value	0 _h

8.5.19 Analogue Input Scaling Integer (6432_h)

This object shall set the scaling in Integer format or input data (6403_h object).

If the object is not supported, the device shall behave accordingly to 642F_h object, or if that object is also not supported, the device shall behave accordingly to the default value.

Note: Configuration of the Analogue Input Scaling Float object (642F_h) shall cause also value change in 6432_h object and vice versa.

Object Description

INDEX	6432 _h
Name	Analogue Input Scaling Integer
Object Code	Array
Data Type	Integer32
Category	Optional

Entry Description

Sub-Index	0 _h
Description	Number of Analogue Inputs
Access	ro
Entry Category	Mandatory
PDO Mapping	No
Value Range	1 _h to FE _h
Default Value	No

Sub-Index	1 _h
Description	Analogue Input 1
Access	rw
Entry Category	Mandatory
PDO Mapping	Optional
Value Range	Integer32
Default Value	1 _h

Sub-Index	2 _h
Description	Analogue Input 2
Access	rw
Entry Category	Optional
PDO Mapping	Optional
Value Range	Integer32
Default Value	1 _h

to

Sub-Index	FE _h
Description	Analogue Input 254
Access	rw
Entry Category	Optional
PDO Mapping	Optional
Value Range	Integer32
Default Value	1 _h

8.6 Analogue output set-ups

8.6.1 (6440_h)

Reserved for compatibility reason.

8.6.2 Analogue Output Offset Float (6441_h)

This object shall set the offset in Float format for output data (6413_h object).

If the object is not supported, the device shall behave accordingly to 6446_h object, or if that object is also not supported, the device shall behave accordingly to the default value.

Note: Configuration of the Analogue Output Offset Integer object (6446_h) shall cause also value change in 6441_h object and vice versa.

Object Description

INDEX	6441 _h
Name	Analogue Output Offset Float
Object Code	Array
Data Type	Float
Category	Optional

Entry Description

Sub-Index	0 _h
Description	Number of Analogue Outputs
Access	ro
Entry Category	Mandatory
PDO Mapping	No
Value Range	1 _h to FE _h
Default Value	No

Sub-Index	1 _h
Description	Analogue Output 1
Access	rw
Entry Category	Mandatory
PDO Mapping	Optional
Value Range	Float
Default Value	0.0

Sub-Index	2 _h
Description	Analogue Output 2
Access	rw
Entry Category	Optional
PDO Mapping	Optional
Value Range	Float
Default Value	0.0

to

Sub-Index	FE _h
Description	Analogue Output 254
Access	rw
Entry Category	Optional
PDO Mapping	Optional
Value Range	Float
Default Value	0.0

8.6.3 Analogue Output Scaling Float (6442_h)

This object shall set the scaling in Float format for output data (6413_h object).

If the object is not supported, the device shall behave accordingly to 6447_h object, or if that object is also not supported, the device shall behave accordingly to the default value.

Note: Configuration of the Analogue Output Scaling Integer object (6447_h) shall cause also value change in 6442_h object and vice versa.

Object Description

INDEX	6442 _h
Name	Analogue Output Scaling Float
Object Code	Array
Data Type	Float
Category	Optional

Entry Description

Sub-Index	0 _h
Description	Number of Analogue Outputs
Access	ro
Entry Category	Mandatory
PDO Mapping	No
Value Range	1 _h to FE _h
Default Value	No

Sub-Index	1 _h
Description	Analogue Output 1
Access	rw
Entry Category	Mandatory
PDO Mapping	Optional
Value Range	Float
Default Value	1.0

Sub-Index	2 _h
Description	Analogue Output 2
Access	rw
Entry Category	Optional
PDO Mapping	Optional
Value Range	Float
Default	1.0

to

Sub-Index	FE _h
Description	Analogue Output 254
Access	rw
Entry Category	Optional
PDO Mapping	Optional
Value Range	Float
Default	1.0

8.6.4 Analogue Output Error Mode (6443_h)

This object defines, whether an output is set to a pre-defined error value (see 6444_h object) in case of an internal device failure or a 'Stop remote node' indication.

0h = actual value rest 1h = reverts to error value integer (6444_h)

others = reserved

If the object is not supported, the device shall behave accordingly to the default value.

Object Description

INDEX	6443 _h
Name	Analogue Output Error Mode
Object Code	Array
Data Type	Unsigned8
Category	Optional

Entry Description

Sub-Index	0 _h
Description	Number of Analogue Outputs
Access	ro
Entry Category	Mandatory
PDO Mapping	No
Value Range	1 _h to FE _h
Default Value	No

Sub-Index	1 _h
Description	Error Mode Analogue Output 1
Access	rw
Entry Category	Mandatory
PDO Mapping	Optional
Value Range	Unsigned8
Default Value	1 _h

Sub-Index	2 _h
Description	Error Mode Analogue Output 2
Access	rw
Entry Category	Optional
PDO Mapping	Optional
Value Range	Unsigned8
Default Value	1 _h

to

Sub-Index	FE _h
Description	Error Mode Analogue Output 254
Access	rw
Entry Category	Optional
PDO Mapping	Optional
Value Range	Unsigned8
Default Value	1 _h

8.6.5 Analogue Output Error Value Integer (6444_h)

On condition that the corresponding Error Mode is active, device failures (see chapter 5.2) shall set the outputs to the value configured by this object.

If the object is not supported, the device shall behave accordingly to 6445_h object, or if that object is also not supported, the device shall behave accordingly to the default value.

Note: Configuration of the Analogue Output Error Value Float object (6445_h) shall cause also value change in 6444_h object and vice versa.

Object Description

INDEX	6444 _h
Name	Analogue Output Error Value Integer
Object Code	Array
Data Type	Integer32
Category	Optional

Entry Description

Sub-Index	0 _h
Description	Number of Analogue Outputs
Access	ro
Entry Category	Mandatory
PDO Mapping	No
Value Range	1 _h to FE _h
Default Value	No

Sub-Index	1 _h
Description	Analogue Output 1
Access	rw
Entry Category	Mandatory
PDO Mapping	Optional
Value Range	Integer32
Default Value	0 _h

Sub-Index	2 _h
Description	Analogue Output 2
Access	rw
Entry Category	Optional
PDO Mapping	Optional
Value Range	Integer32
Default Value	0 _h

to

Sub-Index	FE _h
Description	Analogue Output 254
Access	rw
Entry Category	Optional
PDO Mapping	Optional
Value Range	Integer32
Default Value	0 _h

8.6.8 Analogue Output Error Value Float (6445_h)

On condition that the corresponding Error Mode is active, device failures (see chapter 5.2) shall set the outputs to the value configured by this object.

If the object is not supported, the device shall behave accordingly to 6444_h object, or if that object is also not supported, the device shall behave accordingly to the default value.

Note: Configuration of the Analogue Output Error Value Integer object (6444_h) shall cause also value change in 6445_h object and vice versa.

Object Description

INDEX	6445 _h
Name	Analogue Output Error Value Float
Object Code	Array
Data Type	Float
Category	Optional

Entry Description

Sub-Index	0 _h
Description	Number of Analogue Outputs
Access	ro
Entry Category	Mandatory
PDO Mapping	No
Value Range	1 _h to FE _h
Default Value	No

Sub-Index	1 _h
Description	Analogue Output 1
Access	rw
Entry Category	Mandatory
PDO Mapping	Optional
Value Range	Float
Default Value	0.0

Sub-Index	2 _h
Description	Analogue Output 2
Access	rw
Entry Category	Optional
PDO Mapping	Optional
Value Range	Float
Default Value	0.0

to

Sub-Index	FE _h
Description	Analogue Output 254
Access	rw
Entry Category	Optional
PDO Mapping	Optional
Value Range	Float
Default Value	0.0

8.6.9 Analogue Output Offset Integer (6446_h)

This object shall set the offset in Integer format for output data (6413_h object).

If the object is not supported, the device shall behave accordingly to 6441_h object, or if that object is also not supported, the device shall behave accordingly to the default value.

Note: Configuration of the Analogue Output Offset Float object (6441_h) shall cause also value change in 6446_h object and vice versa.

Object Description

INDEX	6446 _h
Name	Analogue Output Offset Integer
Object Code	Array
Data Type	Integer32
Category	Optional

Entry Description

Sub-Index	0 _h
Description	Number of Analogue Outputs
Access	ro
Entry Category	Mandatory
PDO Mapping	No
Value Range	1 _h to FE _h
Default Value	No

Sub-Index	1 _h
Description	Analogue Output 1
Access	rw
Entry Category	Mandatory
PDO Mapping	Optional
Value Range	Integer32
Default Value	0 _h

Sub-Index	2 _h
Description	Analogue Output 2
Access	rw
Entry Category	Optional
PDO Mapping	Optional
Value Range	Integer32
Default Value	0 _h

to

Sub-Index	FE _h
Description	Analogue Output 254
Access	rw
Entry Category	Optional
PDO Mapping	Optional
Value Range	Integer32
Default Value	0 _h

8.6.10 Analogue Output Scaling Integer (6447_h)

This object shall set the scaling in Integer format for output data (6413_h object).

If the object is not supported, the device shall behave accordingly to 6442_h object, or if that object is also not supported, the device shall behave accordingly to the default value.

Note: Configuration of the Analogue Output Scaling Float object (6442_h) shall cause also value change in 6447_h object and vice versa.

Object Description

INDEX	6447 _h
Name	Analogue Output Scaling Integer
Object Code	Array
Data Type	Integer32
Category	Optional

Entry Description

Sub-Index	0 _h
Description	Number of Analogue Outputs
Access	ro
Entry Category	Mandatory
PDO Mapping	No
Value Range	1 _h to FE _h
Default Value	No

Sub-Index	1 _h
Description	Analogue Output 1
Access	rw
Entry Category	Mandatory
PDO Mapping	Optional
Value Range	Integer32
Default Value	1 _h

Sub-Index	2 _h
Description	Analogue Output 2
Access	rw
Entry Category	Optional
PDO Mapping	Optional
Value Range	Integer32
Default	1 _h

to

Sub-Index	FE _h
Description	Analogue Output 254
Access	rw
Entry Category	Optional
PDO Mapping	Optional
Value Range	Integer32
Default	1 _h

8.6.11 Analogue Output SI Unit (6450_h)

This object shall assign SI units and prefixes for analogue outputs. The structure of the SI unit entry shall be as followed:

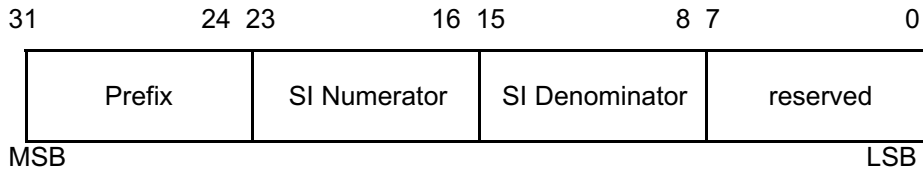

The values for prefix, SI numerator, and SI denominator are specified in /3/.

Object Description

INDEX	6450 _h
Name	Analogue Output SI Unit
Object Code	Array
Data Type	Unsigned32
Category	Optional

Entry Description

Sub-Index	0 _h
Description	Number of Analogue Outputs
Access	ro
Entry Category	Mandatory
PDO Mapping	No
Value Range	1 _h to FE _h
Default Value	No

Sub-Index	1 _h
Description	Analogue Output 1
Access	rw
Entry Category	Mandatory
PDO Mapping	Optional
Value Range	Unsigned32
Default Value	No

Sub-Index	2 _h
Description	Analogue Output 2
Access	rw
Entry Category	Optional
PDO Mapping	Optional
Value Range	Unsigned32
Default Value	No

to

Sub-Index	FE _n
Description	Analogue Output 254
Access	rw
Entry Category	Optional
PDO Mapping	Optional
Value Range	Unsigned32
Default Value	No

8.7 General device profile objects

8.7.1 Device type (67FF)

This object shall describe the first virtual device in a multiple device module according to /2/.

Appendix A: Joystick

This appendix proposes the use of DS-401 for joysticks adopted as a special input module. This input module supports digital inputs and analogue inputs. The digital inputs are the buttons of the joystick and the analogue inputs are the proportional input values. Optional there are digital outputs for indicating LEDs or general purposes..

A1 Pre-defined communication objects for joysticks

A1.1 Index 1000_h (device type)

The specific functionality is defined as a joystick with digital and analogue inputs.

Additional Information		Device Profile Number	Remarks
Specific Functionality	I/O Functionality		
1 _h	5 _h	191 _h	I/O functionality without digital outputs
1 _h	7 _h	191 _h	I/O functionality with digital outputs

A2 Joystick buttons

The buttons use the functionality for digital inputs with 8-bit access. It is mandatory to support 6000_h object and optionally the related configuration objects.

A3 Joystick proportional inputs

The proportional inputs representing the joystick position use the functionality for analogue inputs with signed 16-bit access. An analogue value of zero represents the zero position of the joystick. It is mandatory to support object 6401_h and optionally all related configuration objects.

The default value for the object 6430_h (Analogue Input SI Unit) is:

31	24 23	16 15	8 7	0
00 _h	00 _h	00 _h	00 _h	
MSB			LSB	

A4 Joystick PDO mappings

A4.1 1st TPDO mapping (buttons)

The first TPDO transmits the values of maximum 8 x 8 buttons. The first 8 buttons (Index 6000_h sub-index 1_h) are specified for the following purpose, all other buttons provide manufacturer-specific behaviour:

7							0
unused	unused	unused	unused	unused	memory z-axis	memory y-axis	memory x-axis
MSB						LSB	

The memory buttons for x-, y-, and z-axes shall freeze the proportional values of the related axes:

1 = memory function on (freeze proportional values)

0 = memory function off (release proportional values)

It is optional to include the freezing function into the joystick itself. In this case the proportional values will not be modified any more if the memory function is switched on.

Otherwise freezing must be done by the application and the Buttons must be interpreted as freezing request. In this case the memory buttons have no effect on the proportional input values.

If the joystick does not support memory function, the first digital input byte (Object 6000_h Sub-index 1_h) remains unused and will be forced to 0.

A4.2 2nd TPDO mapping (proportional inputs)

The second TPDO transmits the 16-bit values of maximum 4 proportional inputs. The first 3 analogue values (Index 6010_h sub-index 1_h .. 3_h) are used for the three dimensions (x, y, z), the other analogue value is manufacturer-specific.

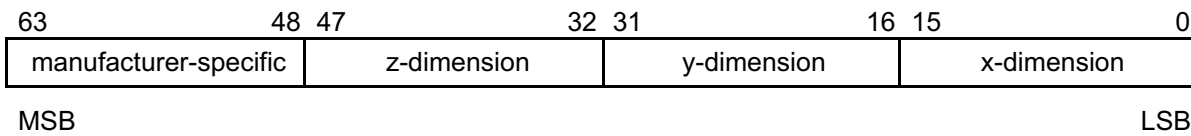

A4.3 Joystick implementation hints

A4.3.1 Periodical PDO transmission

If periodical PDO transmission is requested, the event timer should be set to $\neq 0$.

A4.3.2 Additional proportional inputs

If additional proportional inputs are required, the pre-defined 3rd and 4th TPDO should be used.

A4.3.3 Transmission of proportional inputs

In order to transmit only the first proportional value different from 0, the analogue input set-up objects should be used.